

CARAT



CUTTING

GRINDING

DRILLING

DUST FREE WORKING

CATALOGUE 2021



CARAT NEDERLAND B.V.

Nikkelstraat 18
4823 AB Breda
The Netherlands

CoC Breda H20061250
VAT no. 008546368B01

Sales

Tel: +31 (0)76 5 422 422
sales@carat-tools.nl

www.carat-tools.eu



CARAT

DIAMOND BLADES

	Page
Choosing the right diamond blade	2

MACHINE TYPE

Angle grinder - Wall chaser	
For universal use	4
For concrete and hard stone materials	10
For brick and asphalt	12

Angle grinder

For tiles and natural stone	14
For plastics	17

Angle grinder - Circular saw

For fibre cement materials	20
For concrete and natural stone	20

Cut-off grinder - Floor saw

For universal use	21
For concrete and hard stone materials	23
For brick and asphalt	25
For universal use and tiles	26

Table saw - Wall saw - Cut off saw

For universal use	27
For concrete and hard stone materials	28
For brick and asphalt	29

Table saw - Tile saw

For tiles and natural stone	30
-----------------------------	----

CARAT

Four key questions when choosing the right diamond blade:

1

What machine is it for?

A pictogram shows which machines the diamond blade can be used on.



2

What material is it for?

The Carat diamond blade range has five colour codes that clearly indicate the applications:

UNIVERSAL, VARIOUS STONE MATERIALS

Diamond blades suitable for alternate cutting of medium-hard to hard stone. This saves time because you do not have to swap diamond blades when cutting different types of stone.



CONCRETE, HARD STONE MATERIALS

Ideally suited for continuous cutting of reinforced concrete, pebble-dashed concrete, concrete blocks, granite, paving bricks and all other hard or very hard types of stone.



BRICK, ASPHALT

For cutting soft, abrasive stone materials such as bricks, sand-lime bricks, asphalt or concrete less than 28 days old.



TILES, STONE

For cutting wall and floor tiles and natural stone such as marble or granite. The fine teeth or continuous rim guarantees a perfectly finished saw cut.



ETERNIT® SIDINGS®, FIBRE CEMENT PANELS

Diamond blades for cutting wall facade elements made of fibre cement and Eternit® Sidings®.



3

Which quality?

The number of diamonds stated for the diamond blades indicates the quality level. The more diamonds there are in the bar, the higher the quality and the better the performance.

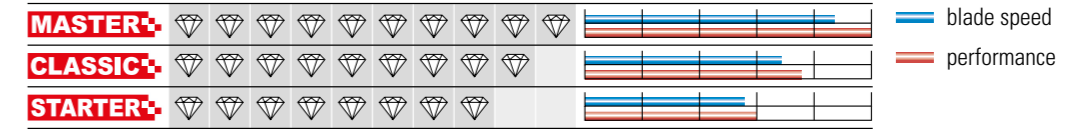

4

With or without water cooling?

These diamond blades **MUST** be cooled with water (not suitable for dry use).



Suitable for dry use. However, these diamond blades can also be cooled with water, which extends the lifespan of the blade.

i

Properties of sawing blades, grinding heads and tuck point (flush cutting) blades

- Segment height.
- LASER Laser-welded, 100% guarantee against weld breakage.
- PROTECTION Protection segment.
- DIATEX Diatex.
- TURBO-TWISTED Turbo-twisted.
- SILENT+ Sandwich blade: specially developed for extreme noise reduction.
- SILENT Noise reduction.
- Segment width.

What is Diatex?

When these segments are produced, the diamonds are placed in a controlled pattern. The distance between each diamond is identical and they are stacked in layers throughout the segment. After one layer is worn off, an entirely new layer will appear. This process means that every diamond is 100% used, which significantly increases the lifespan and blade speed.





ANGLE GRINDER – WALL CHASER

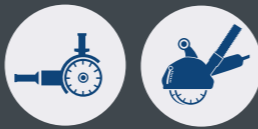

UNIVERSAL ALL-ROUNDER **MASTER+**

- Cuts anything! Reinforced concrete, all hard stone types, ceramic and sand-lime bricks, steel, iron etc.



Ø mm	Arbor hole Ø mm	Article code
125	22.23	CEB1253010
230	22.23	CEB2303015

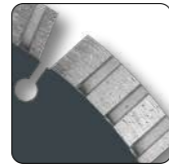

UNIVERSAL CE **MASTER+**

- Cuts super fast through all materials.
- High performance.
- Fitted with 3 specific diamond segments: concrete, universal and brick segments.



Ø mm	Arbor hole Ø mm	Article code
115	22.23	CEM1153000
125	22.23	CEM1253000
140	22.23	CEM1403000
150	22.23	CEM1509000
180	22.23	CEM1803000
230	22.23	CEM2303000



ANGLE GRINDER – WALL CHASER



UNIVERSAL CE **CLASSIC**

- Cuts super fast through all materials.
- High performance.



Ø mm	Arbor hole Ø mm	Article code
115	22.23	CEC1153000
125	22.23	CEC1253000
150	22.23	CEC1509000
180	22.23	CEC1803000
230	22.23	CEC2303000



UNIVERSAL CEE **STANDARD**

- Perfect performance.
- Semi-professional laser welded diamond blade.
- Cost-effective.



Ø mm	Arbor hole Ø mm	Article code
115	22.23	CEE1153010
125	22.23	CEE1253010
150	22.23	CEE1509010
180	22.23	CEE1803010
230	22.23	CEE2303010





ANGLE GRINDER – WALL CHASER



UNIVERSAL CE **STARTER**

- Semi-professional diamond dry cut blade.
- Cost-effective diamond blade.

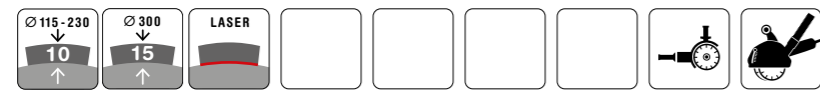

Ø mm	Arbor hole Ø mm	Article code
115	22.23	CES1153000
125	22.23	CES1253000
140	22.23	CES1403000
150	22.23	CES1509000
230	22.23	CES2303000
300	22.23	CES3003000



BLUE DIAMOND UNIVERSAL

- Blade for use without water cooling.
- Suitable for alternately cutting of medium-hard to hard materials.

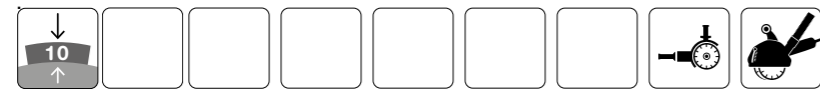

Ø mm	Arbor hole Ø mm	Article code
115	22.23	CEBD115310
125	22.23	CEBD125310
140	22.23	CEBD140310
150	22.23	CEBD150910
180	22.23	CEBD180310
230	22.23	CEBD230310



ANGLE GRINDER – WALL CHASER



UNIVERSAL CDZS STANDARD

- Continuous segment for a better finish to the cut.



Ø mm	Arbor hole Ø mm	Article code
115	22.23	CDZS115300
125	22.23	CDZS125300
150	20.00	CDZS150200
150	22.23	CDZS150900
180	22.23	CDZS180300
230	22.23	CDZS230300

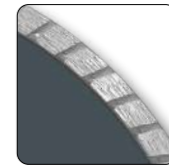

UNIVERSAL CEB THUNDERLINE

- Cuts super fast through all materials.
- High performance.



Ø mm	Arbor hole Ø mm	Article code
115	22.23	CEB11530TT
125	22.23	CEB12530TT
140	22.23	CEB14030TT
150	22.23	CEB15090TT
180	22.23	CEB18030TT
230	22.23	CEB23030TT





ANGLE GRINDER – WALL CHASER

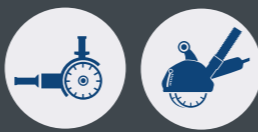

UNIVERSAL GOLD

- Cost-effective universal diamond blades in 3 quality levels.



Ø mm	Arbor hole Ø mm	Article code
115	22.23	CEG1153010
125	22.23	CEG1253010
150	22.23	CEG1509012
180	22.23	CEG1803012
230	22.23	CEG2303012



UNIVERSAL SILVER



Ø mm	Arbor hole Ø mm	Article code
115	22.23	CESI115310
125	22.23	CESI125310
150	22.23	CESI150912
180	22.23	CESI180312
230	22.23	CESI230312



UNIVERSAL BRONZE



Ø mm	Arbor hole Ø mm	Article code
115	22.23	CEBR115310
125	22.23	CEBR125310
150	22.23	CEBR150910
180	22.23	CEBR180310
230	22.23	CEBR230310



ANGLE GRINDER



UNIVERSAL CVUN DUAL PREMIUM

- For grinding and cutting hard and soft materials.
- Suitable for all types of angle grinders with M14 connection to reach even the most difficult places.



Ø mm	Connector	Article code
125	M14	CVUN125M00
230	M14	CVUN230M00

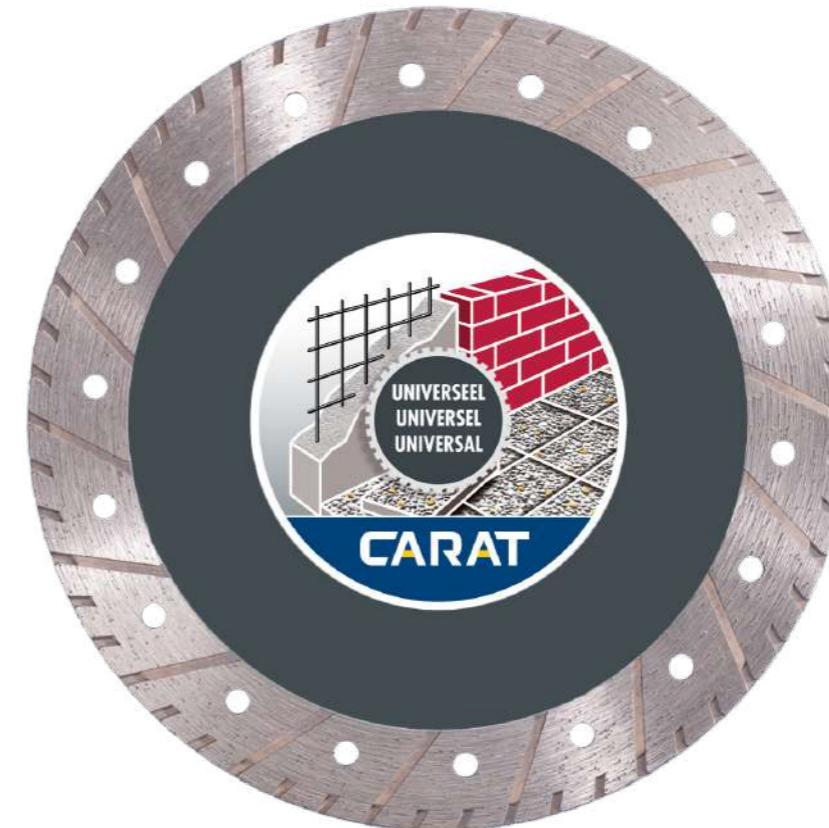

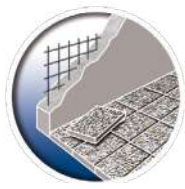

ANGLE GRINDER – WALL CHASER



CONCRETE CS **MASTER**

- High-performance blade with very fast cutting turbo segment.



Ø mm	Arbor hole Ø mm	Article code
115	22.23	CSM1153000
125	22.23	CSM1253000
140	22.23	CSM1403000
150	22.23	CSM1509000
180	22.23	CSM1803000
230	22.23	CSM2303000

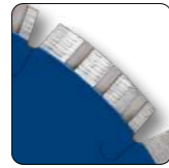

CONCRETE CS **CLASSIC**

- For hard and very hard stone materials such as concrete, pebble-dashed concrete and paver bricks.



Ø mm	Arbor hole Ø mm	Article code
115	22.23	CSC1153000
125	22.23	CSC1253000
150	22.23	CSC1509000
230	22.23	CSC2303000



ANGLE GRINDER – WALL CHASER



CONCRETE TURBO CDT **MASTER**

- Revolutionary blade with special protective segments that reduce friction in the cut, letting the blade remain cooler and more stable.



Ø mm	Arbor hole Ø mm	Article code
115	22.23	CDTM115300
125	22.23	CDTM125300
180	22.23	CDTM180300
230	22.23	CDTM230300



CONCRETE TURBO CDTs **CLASSIC**

- Corrugated blade with holes for extra air cooling, keeping the blade more stable.



Ø mm	Arbor hole Ø mm	Article code
115	22.23	CDTSC11530
125	22.23	CDTSC12530
150	22.23	CDTSC15090
180	22.23	CDTSC18030
230	22.23	CDTSC23030

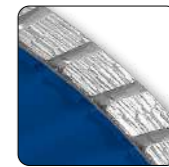



ANGLE GRINDER – WALL CHASER

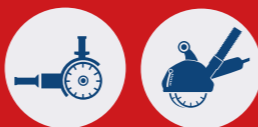

BRICK / ASPHALT CA **MASTER**

- Diamond blade with protective segments to prevent undercutting.



Ø mm	Arbor hole Ø mm	Article code
115	22.23	CAM1153000
125	22.23	CAM1253000
140	22.23	CAM1403000
150	22.23	CAM1509000
180	22.23	CAM1803000
230	22.23	CAM2303000



BRICK / ASPHALT CA **CLASSIC**

- For abrasive, sandy stone materials such as sand-lime bricks and asphalt.



Ø mm	Arbor hole Ø mm	Article code
115	22.23	CAC1153000
125	22.23	CAC1253000
150	22.23	CAC1509000
230	22.23	CAC2303000



ANGLE GRINDER



RENOVATOR UNIVERSAL

- With the TCT (tungsten carbide tips) teeth this blade is essential for every renovation specialist.
- Cuts through tree roots, thin metal plates, nails, screws, rubber and bitumen.



Ø mm	Arbor hole Ø mm	Article code
125	22.23	CREN125300
230	22.23	CREN230300

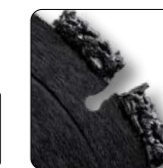



ANGLE GRINDER



TILES / STONE CDB **RACER**

- Cuts tiles and stone extremely fast and without leaving serrations.
- Thin segment: 1.2 mm.

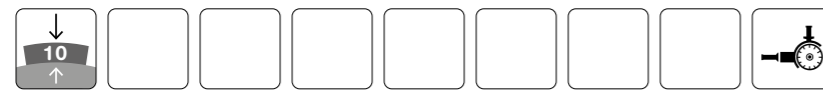

Ø mm	Arbor hole Ø mm	Article code
115	22.23	CDB1153000
125	22.23	CDB1253000
230	22.23	CDB2303000

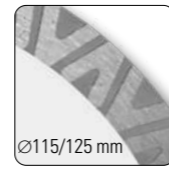

ANGLE GRINDER



TILES CSM **MASTER**

- Extremely thin and fast tile blade for natural stone.



Ø mm	Arbor hole Ø mm	Article code
115	22.23	CSMM115300
125	22.23	CSMM125300

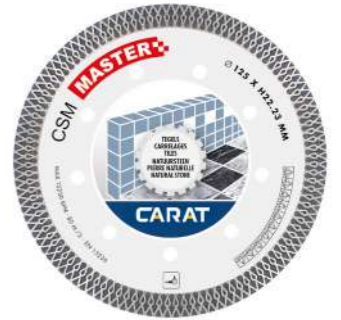
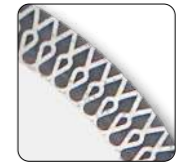

TILES CSM **CLASSIC**

- Suitable for hard tiles.



Ø mm	Arbor hole Ø mm	Article code
115	22.23	CSMC115300
125	22.23	CSMC125300



TILES CDB **STARTER**

- Suitable for hard tiles.



Ø mm	Arbor hole Ø mm	Article code
115	22.23	CDBS115300
125	22.23	CDBS125300





ANGLE GRINDER



TILES BLUE DIAMOND

- Tile blade for softer tiles.



Ø mm	Arbor hole Ø mm	Article code
110	22.23	CSMS1103BD
125	22.23	CSMS1253BD



DUAL MASTER

- For grinding and cutting tiles, natural stone and other hard stony materials.
- Suitable for all angle grinders with an M14 connector.



Ø mm	Connector	Article code
125	M14	CVNS125M000
230	M14	CVNS230M000



ANGLE GRINDER



GALVANO CEPS CLASSIC

- For cutting marble and plastics such as polyester and fibreglass.
- With slotted rim.



Ø mm	Arbor hole Ø mm	Article code
100	22.23	CEPS100300
115	22.23	CEPS115300
125	22.23	CEPS125300
150	22.23	CEPS150300
180	22.23	CEPS180300
230	22.23	CEPS230300



GALVANO CEPC CLASSIC

- For cutting marble and plastics such as polyester and fibreglass.
- With continuous rim.



Ø mm	Arbor hole Ø mm	Article code
100	22.23	CEPC100300
115	22.23	CEPC115300
125	22.23	CEPC125300
180	22.23	CEPC180300
230	22.23	CEPC230300





PIPE CUTTER CVPC CLASSIC

- Cutting off and fettling plastic pipes in a single action.



Ø mm	Arbor hole Ø mm	Article code
125	22.23	CVPC125300



X-LOCK

- X-tra handy: changing accessories with angle grinders has never been easier.
- X-tra revolutionary: can be changed with just one click.
- X-tra reliable: diamond blades cannot be mounted incorrectly.
- For use on Bosch and other X-lock angle grinders, but also on angle grinders with a standard arbor hole 22.23 mm.



Ø mm	Arbor hole Ø mm	Application	Article code
125	22.23	Concrete	CCXLOCK125
125	22.23	Universal	CUXLOCK125
125	22.23	Brick	CAXLOCK125
125	22.23	Tiles	CTXLOCK125

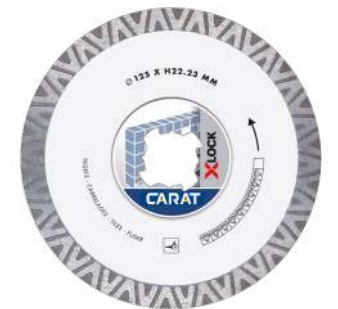



ANGLE GRINDER – CIRCULAR SAW



CUT-OFF GRINDER – FLOOR SAW



ETERNIT CDCE **MASTER**

- Suitable for cutting fibre cement facade elements and Eternit® Sidings®.



Ø mm	Arbor hole Ø mm	Article code
125	22.23	CDCE125300
150	20.00	CDCE150200
150	22.23	CDCE150300
150	30.00	CDCE150500
180	22.23	CDCE180300
180	30.00	CDCE180500
200	25.40	CDCE200400
200	30.00	CDCE200500
230	25.40	CDCE230400
230	30.00	CDCE230500
250	30.00	CDCE250500
300	30.00	CDCE300500

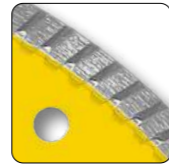

CONCRETE / STONE CDTC **CLASSIC**

- Suitable for TC-1800 handheld tile saw machines and angle grinders.



Ø mm	Arbor hole Ø mm	Article code
180	22.23	CDTC180300



UNIVERSAL CE **STARTER**

- Diamond blade at an affordable price.



Ø mm	Arbor hole Ø mm	Article code
300	20.00	CES3002000
300	22.23	CES3003000
300	25.40	CES3004000
350	20.00	CES3502000
350	25.40	CES3504000
400	20.00	CES4002000
400	25.40	CES4004000

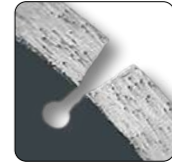

UNIVERSAL CEB **THUNDERLINE**

- Cuts super fast through all materials.
- High performance.



Ø mm	Arbor hole Ø mm	Article code
300	20.00	CEB30020TT
300	22.23	CEB30030TT
300	25.40	CEB30040TT
350	20.00	CEB35020TT
350	25.40	CEB35040TT
400	25.40	CEB40040TT





CUT-OFF GRINDER – FLOOR SAW



RENOVATOR UNIVERSAL

- With the TCT (tungsten carbide tips) teeth this blade is essential for every renovation specialist.
- Cuts through tree roots, thin metal plates, nails, screws, rubber and bitumen.



Ø mm	Arbor hole Ø mm	Article code
300	20.00	CREN300200
350	20.00	CREN350200
350	25.40	CREN350400
400	20.00	CREN400200
400	25.40	CREN400400



CUT-OFF GRINDER – FLOOR SAW



CONCRETE CRB MASTER+

- High performance cutting blade.
- For both wet and dry use.



Ø mm	Arbor hole Ø mm	Article code
300	20.00	CRBM300200
300	22.23	CRBM300300
300	25.40	CRBM300400
350	20.00	CRBM350200
350	25.40	CRBM350400
400	20.00	CRBM400200
400	25.40	CRBM400400
450	25.40	CRBM450400
500	25.40	CRBM500400
600	25.40	CRBM600400

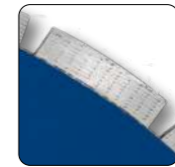

CONCRETE CS MASTER+

- Very fast cutting turbo segment.
- For both wet and dry use.



Ø mm	Arbor hole Ø mm	Article code
300	20.00	CSM3002000
300	22.23	CSM3003000
300	25.40	CSM3004000
350	20.00	CSM3502000
350	25.40	CSM3504000
400	20.00	CSM4002000
400	25.40	CSM4004000
400	25.40	CSM4004BF0





CONCRETE CS CLASSIC

- For hard and very hard stone materials such as concrete, pebble-dashed concrete and paver bricks.
- For both wet and dry use.



Ø mm	Arbor hole Ø mm	Article code
300	20.00	CSC3002000
350	20.00	CSC3502000
350	25.40	CSC3504000
400	20.00	CSC4002000
400	25.40	CSC4004000



CONCRETE CS XL CLASSIC

- Extremely suitable for continuous cutting in reinforced concrete.
- Very fast-cutting turbo segment.
- Arbor hole 25.40 mm with fitting ring to 20.00 mm.



Ø mm	Arbor hole Ø mm	Article code
350	25.40/20.00	CSCXL35042
400	25.40/20.00	CSCXL40042



ASPHALT CA MASTER

- Top quality asphalt blade with tilted segments for optimal protection of the core of the blade.
- For both wet and dry use.

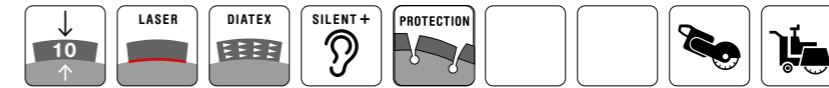

Ø mm	Arbor hole Ø mm	Article code
300	20.00	CAM3002000
300	25.40	CAM3004000
350	20.00	CAM3502000
350	25.40	CAM3504000
400	20.00	CAM4002000
400	25.40	CAM4004000
450	25.40	CAM4504000
500	25.40	CAM5004000
600	25.40	CAM6004000



BRICK / ASPHALT CA CLASSIC

- Diamond blade with tilted protective segments.
- For both wet and dry use.



Ø mm	Arbor hole Ø mm	Article code
300	20.00	CAC3002000
300	22.23	CAC3003000
350	20.00	CAC3502000
350	25.40	CAC3504000
400	20.00	CAC4002000





CUT-OFF GRINDER



TABLE SAW – WALL SAW – CUT-OFF SAW



TILES CSM **MASTER+**

• Ideally suited for cutting the hardest ceramic tiles.



Ø mm	Arbor hole Ø mm	Article code
300	20.00	CSMM300200
350	20.00	CSMM350200



UNIVERSAL CNE **MASTER+**

• Very fast and high performance.

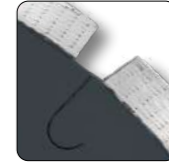

Ø mm	Arbor hole Ø mm	Article code
300	25.40	CNEM300400
300	30.00	CNEM300500
350	25.40	CNEM350400
350	30.00	CNEM350500
370	30.00	CNEM370500
400	25.40	CNEM400400
450	25.40	CNEM450400
500	25.40	CNEM500400
600	25.40	CNEM600400



UNIVERSAL CNE **CLASSIC+**

• With serrated segments to optimise the first cut.



Ø mm	Arbor hole Ø mm	Article code
300	25.40	CNEC300400
300	30.00	CNEC300500
350	25.40	CNEC350400
350	30.00	CNEC350500
370	30.00	CNEC370500





TABLE SAW – WALL SAW – CUT-OFF SAW



CONCRETE CNC **MASTER**

- Very fast and high performance.



Ø mm	Arbor hole Ø mm	Article code
300	25.40	CNCM300400
300	30.00	CNCM300500
350	25.40	CNCM350400
350	30.00	CNCM350500
370	30.00	CNCM370500
400	25.40	CNCM400400
450	25.40	CNCM450400
500	25.40	CNCM500400
600	25.40	CNCM600400



TABLE SAW – WALL SAW – CUT-OFF SAW



BRICK / ASPHALT CNA **MASTER**

- Very fast and high performance.



Ø mm	Arbor hole Ø mm	Article code
300	25.40	CNAM300400
300	30.00	CNAM300500
350	25.40	CNAM350400
350	30.00	CNAM350500
370	30.00	CNAM370500
400	25.40	CNAM400400
450	25.40	CNAM450400
500	25.40	CNAM500400
600	25.40	CNAM600400

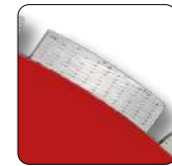

CONCRETE CNC **CLASSIC**

- With serrated segments to optimise the first cut.



Ø mm	Arbor hole Ø mm	Article code
300	25.40	CNCC300400
300	30.00	CNCC300500
350	25.40	CNCC350400
350	30.00	CNCC350500
370	30.00	CNCC370500



BRICK / ASPHALT CNA **CLASSIC**

- With serrated segments to optimise the first cut.



Ø mm	Arbor hole Ø mm	Article code
300	25.40	CNAC300400
300	30.00	CNAC300500
350	25.40	CNAC350400
350	30.00	CNAC350500
370	30.00	CNAC370500





TILES / STONE CDC MASTER

• For cutting very hard wall and floor tiles fast.



Ø mm	Arbor hole Ø mm	Article code
150	20.00	CDCM150200
150	22.23	CDCM150300
180	22.23	CDCM180300
180	25.40	CDCM180400
200	25.40	CDCM200400
200	30.00	CDCM200500
230	25.40	CDCM230400
250	25.40	CDCM250400
300	25.40	CDCM300400
300	30.00	CDCM300500
350	25.40	CDCM350400
350	30.00	CDCM350500

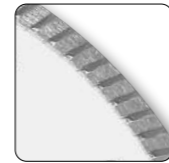

TILES CSM MASTER

• Ideally suited for cutting the hardest ceramic tiles.



Ø mm	Arbor hole Ø mm	Article code
300	25.40	CSMM300400
300	30.00	CSMM300500
350	25.40	CSMM350400
350	30.00	CSMM350500



NATURAL STONE CNT CLASSIC

• Ideally suited for the most common types of natural stone such as marble, granite and blue stone.



Ø mm	Arbor hole Ø mm	Article code
250	25.40	CNTC250400
300	25.40	CNTC300400
300	30.00	CNTC300500
350	25.40	CNTC350400
350	30.00	CNTC350500



TILES CSM CLASSIC

• Suitable for hard tiles.



Ø mm	Arbor hole Ø mm	Article code
150	22.23	CSMC150300
150	25.40	CSMC150400
180	25.40	CSMC180400
200	25.40	CSMC200400
230	25.40	CSMC230400
250	25.40	CSMC250400
300	25.40	CSMC300400
300	30.00	CSMC300500
350	25.40	CSMC350400
350	30.00	CSMC350500

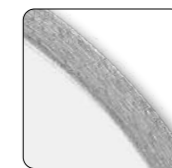



TUCK POINT BLADES AND GRINDING CUP

	Page
Angle grinder	
Diamond tuck point blades	34
Angle grinder - Concrete grinder	
Diamond grinding cup	38
Floor grinding machine	
Diamond grinding cup	43



ANGLE GRINDER



SOFT JOINTS CTC MASTER+

- For grinding soft cement joints.
- Long protective segments to prevent wear off the core.

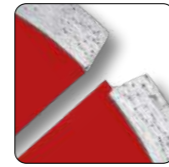
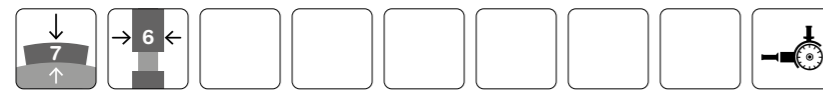

Ø mm	Arbor hole Ø mm	Article code
115	22.23	CTC1153000
125	22.23	CTC1253000

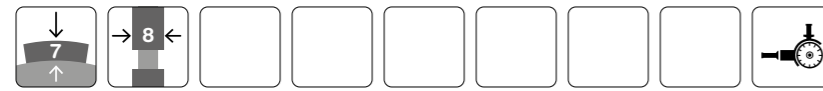

125	22.23	CTC1253008
-----	-------	------------



SOFT JOINTS CTC CLASSIC+

- Semi-professional use (alternative to type CTC Master).



Ø mm	Arbor hole Ø mm	Article code
115	22.23	CTCC115300
125	22.23	CTCC125300



SOFT JOINTS STC MASTER+

- With zigzag segments.
- For grinding wider soft cement joints.



Ø mm	Arbor hole Ø mm	Article code
125	22.23	STC1253008



ANGLE GRINDER



HARD JOINTS CTP MASTER+

- For grinding medium to hard cement joints.
- Long protective segments to prevent wear off the core.

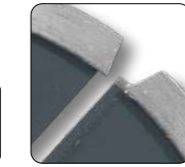

Ø mm	Arbor hole Ø mm	Segment width mm	Article code
80	22.23	4	CTP0803000
115	22.23	6	CTP1153000
125	22.23	6	CTP1253000
180	22.23	6	CTP1803000



HARD JOINTS CTY CLASSIC+

- For grinding hard cement joints with a big angle grinder.



Ø mm	Arbor hole Ø mm	Segment width mm	Article code
230	22.23	6	CTY2303006
230	22.23	8	CTY2303008



HARD JOINTS CTP CLASSIC+

- Semi-professional use (alternative to type CTP Master).



Ø mm	Arbor hole Ø mm	Segment width mm	Article code
115	22.23	6	CTPC115300
125	22.23	6	CTPC125300





PIPE CUTTING BLADE

- For brick walls.
- Pipe cutting wide 19 mm.

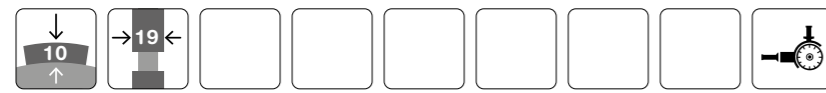

Ø mm	Arbor hole Ø mm	Article code
125	22.23	CTC1253019



CRACK CHASER BLADE CCC CLASSIC

- Suitable for milling cracks.
- For concrete.



Ø mm	Connector	Article code
92	M14	CCC090MC00



FLOOR HEATING TUCK-POINT HARD

- Special diamond tuck-point blade for floor heating milling machines.
- Extremely long lifetime.

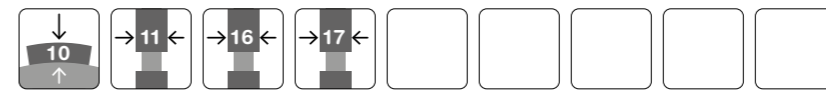

Ø mm	Arbor hole Ø mm	Segment width mm	Article code
115	22.23	11	CFH115301120
115	22.23	16	CFH115301620
115	22.23	17	CFH115301720



FLOOR HEATING TUCK-POINT SOFT

- Special diamond tuck-point blade for floor heating milling machines.
- Extremely long lifetime.



Ø mm	Arbor hole Ø mm	Segment width mm	Article code
115	22.23	16	CFJ115301610
115	22.23	17	CFJ115300010



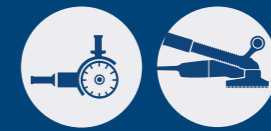
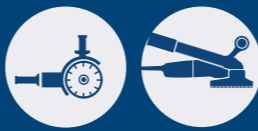

DUSTEC® GRINDING CUPS

- High quality, extreme longevity. Double row of segments.
- The holes in the core make the grinding cup suitable for machines with dust extraction such as the Carat type BS-125.. / BS-180.. concrete grinder.
- Available in 2 types: concrete and brick.



CONCRETE CUBD MASTER

- For grinding concrete and hard stone materials.

Ø mm	Arbor hole Ø mm	Article code
125	22.23	CUBD1253C0
125	25.00	CUBD1259C0
180	22.23	CUBD1803C0



CONCRETE CUBC CLASSIC

- With long and short segments • Work fast with high performance.



Ø mm	Arbor hole Ø mm	Article code
125	22.23	CUBC1253C0
180	22.23	CUBC1803C0



BRICK CUBD MASTER

- For grinding soft, sandy types of stone.



Ø mm	Arbor hole Ø mm	Article code
125	22.23	CUBD1253A0
180	22.23	CUBD1803A0



CONCRETE CUBF ABSORBER MASTER

- Anti-vibration grinding cup • Less stressful because of low vibration flange.



Ø mm	Connector	Article code
125	M14	CUBF125M00



CONCRETE CUM MASTER

- Wide segment layout for even grinding.
- High quality and extreme longevity.
- The holes in the core make the grinding cup suitable for machines with dust extraction such as the Carat type BS-125.. / BS-180.. concrete grinder.



Ø mm	Arbor hole Ø mm	Article code
100	22.23	CUM1003C00
110	15.00	CUM1101C00
125	22.23	CUM1253C00
180	22.23	CUM1803C00

Ø mm	Connector	Article code
100	M14	CUM100MC00
125	M14	CUM125MC00



CONCRETE CUC MASTER

- Small diameters for corners or hard-to-reach places.



Ø mm	Connector	Article code
50	M14	CUC050M000
80	M14	CUC080M000



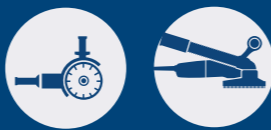

CONCRETE DF MASTER

- High diamond density for fast work.
- Perfect finish and a long lifespan.
- The holes in the core make the grinding cup suitable for machines with dust extraction such as the Carat type BS-125.. / BS-180.. concrete grinder.



Ø mm	Arbor hole Ø mm	Article code
115	22.23	CUDF115300
125	22.23	CUDF125300
180	22.23	CUDF180300



CONCRETE DG CLASSIC

- Single row of segments.
- The holes in the core make the grinding cup suitable for machines with dust extraction such as the Carat type BS-125.. / BS-180.. concrete grinder.



Ø mm	Arbor hole Ø mm	Article code
115	22.23	CUDG115300
125	22.23	CUDG125300
180	22.23	CUDG180300

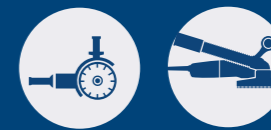

CUBG STAR MASTER

- Special segment design.
- The big gaps between the segments ensures a perfect dust extraction.
- Universal use on concrete, granite and cover floors.



Ø mm	Arbor hole Ø mm	Article code
125	22.23	CUBG1253C0
180	22.23	CUBG1803C0

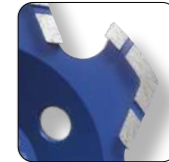

ULTRONE FAST GRINDER CUP CUFC MASTER

- Universal grinder cup for concrete and brick, for removing glue residues, bitumen, paint, carpet residues and epoxy.
- The holes in the core make the grinding head suitable for machines with dust extraction such as the Carat type BS-125.. / BS-180.. concrete grinder.



Ø mm	Arbor hole Ø mm	Article code
125	22.23	CUFC125300
150	22.23	CUFC150300
180	22.23	CUFC180300



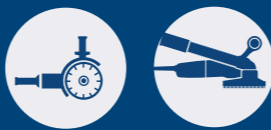

CONCAVE BLADE

- Universal.
- Allows cutting in circles around sewers and wells.

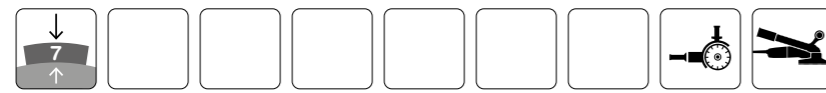

Ø mm	Arbor hole Ø mm	Article code
125	22.23	CHS1253000
230	22.23	CHS2303000



PCD GRINDING CUP MASTER

- Segments from the latest PCD (polycrystalline diamond) generation.
- Removes glue residue, bitumen, paint, carpet residue, epoxy and other non-ferrous materials.
- The holes in the core make the grinding cup suitable for machines with dust extraction such as the Carat type BS-125.. / BS-180.. concrete grinder.



Ø mm	Arbor hole Ø mm	Article code
125	22.23	CPCD125300
180	22.23	CPCD180300



GRINDING CUP CUBHC HARD CONCRETE

- Grinding cup for floor grinding machine.
- Universal connection with 19 mm arbor hole and sunken M12.
- 20 diamond segments 40 x 10 x 10 mm.



Ø mm	Arbor hole Ø mm	Article code
250	19	CUBHC25000

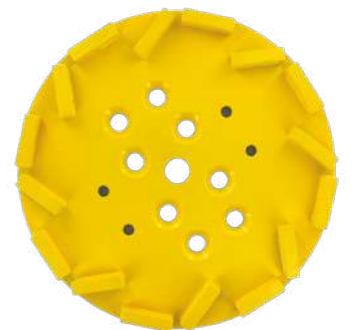



MACHINES

	Page
For tilers	
Tile saw machines	46
Bridge saw machines	51
Tile cutters	52
Tile levelling system	54
Mixers	55
For building contractors	
Stone saw machines	57
Wall saw machines	64
Cut-off grinder	65
Ring saw machine	66
Cut off saw	67
Wall chaser machines	68
Tuck point cutters	72
Concrete grinders	73
Floor saw machines	77



MICROCOUP 180 ALU

- Compact tile saw machine.
- Large cast aluminum worktop.
- Includes CSMC diamond blade Ø 180 mm.

Technical data	
Power kW (hp)	: 0.75 (1.0)
Voltage V	: 230
Ø saw blade mm	: 180 x 25.40
Max. material thickness cm	: 3
Weight kg	: 16
Article code	: BUJ180A000

TILES p. 30/31



Adjustable material guide



Mitre cutting



Cable holder



Simple transport



Water cooling



Dust extraction



Guide rail with clamps



Adjustable height



TC-1800

- Hand-held saw machine on a rail.
- For perfect cutting of stone and (concrete) tiles.
- PRCD switch, soft-start and overload safety.
- Includes CDTC diamond blade Ø 180 mm, case and guide rail.

Technical data	
Power kW (hp)	: 1.8 (2.5)
Voltage V	: 230
Ø saw blade mm	: 180 x 22.23
Max. material thickness cm	: 5.5
Weight kg	: 6.7

AVAILABLE IN TWO VARIANTS:

Machine including three 40cm rails and connectors	
Article code	: MZMB18APRO
Machine including one 140cm rail	
Article code	: MZMB18AREN

ACCESSORIES

Description	Article code
Guide rail 40 cm	MZMBAR0400
Guide rail 140 cm	MZMBAR1400
Rail clamp	MZMBAK0000
Rail coupling	MZMBARK000
Diamond blade Ø 180 mm	CDTC180300

TILES/STONE p. 20



CARACOUP

- Professional machines for extremely precise cutting.
- Adjustable material guide with angle adjustment.
- Including fold-away support and CDCM diamond blade Ø 200 mm.



Plunge cutting



Mitre cutting

Technical data		
Power kW (hp)	: 1.0 (1.3)	
Voltage V	: 230	
Ø saw blade mm	: 200 x 25.40	
Max. material thickness cm	: 4	
	Caracoup 265	Caracoup 295
Max. cutting length cm	65	95
Maximum tile size (diagonal) cm	42 x 42	63 x 63
Weight kg	34	39
Article code	BUK2650000	BUK2950000
Description		Article code
Side table		BUKS000000

TILES/STONE p. 30/31





CARACOU ALU

- Revolutionary tile saw machine with laser ruler.
- Durable high-tech construction in aluminum and ABS.
- Up to 20% lighter than conventional machines.
- Fitted with professional material guide for the most precise finishing.
- Including fold-away support, casters and diamond blade Ø 200 mm.

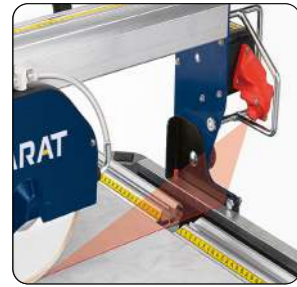

Laser ruler



Tile lock system

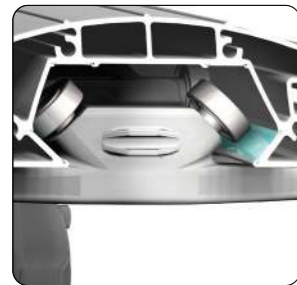

8 ball bearings



Mitre cutting

Technical data

Ø saw blade mm	: 200 x 25.40
Max. material thickness cm	: 4

Description

Description	Article code
Side table	BUCCT00000
Tile lock system	BPK4000000
Material clamp 2067	BUCCTB1000
Material clamp 2090	BUCCTB0000
Material clamp 85 ALU	BUCCTB0850
Material clamp 105 ALU	BUCCTB1050
Material clamp 130 ALU	BUCCTB1300

TILES/STONE p. 30/31



Caracoup	2067 ALU	2090 ALU	85 ALU	105 ALU	130 ALU
Voltage V	230	230	230	230	230
Power kW (hp)	1.0 (1.3)	1.0 (1.3)	1.4 (1.8)	1.4 (1.8)	1.4 (1.8)
Max. cutting length cm	67	90	85	105	130
Max. tile cut (diagonal) cm	45 x 45	62 x 62	60 x 60	74 x 74	88 x 88
Weight kg	40	44	45	49	54
Max. material thickness cm	4	4	4	4	4
Article code	BUCC2067LO	BUCC2090LO	BUCC850000	BUCC105000	BUCC130000

P-3500 LASER

- Durable high-tech construction in aluminum and ABS.
- Includes side table and extended material guide.
- Up to 20% lighter than conventional machines.
- Also available with 400V motor.
- Ideal for cutting stone and concrete tiles.



Laser ruler



Hand wheel



Mitre cutting



Tile lock system

Technical data

Power kW (hp)	: 2.3 (3.0)
Voltage V	: 230
Ø saw blade mm	: 350 x 25.40
Transport dimensions W x H cm	: 80 x 81

Accessories

Accessories	Article code
Machine cover P-3510	BPHOES0000
Tile lock system	BPK4000000

- UNIVERSAL p. 27
- CONCRETE p. 28
- BRICK p. 29
- TILES/STONE p. 30/31



	P-3508	P-3510	P-3512	P-3515	P-3520
Max. cutting length cm	80	100	120	150	200
Max. material thickness cm	11	11	11	11	11
Transport length cm	160	176	198	230	275
Weight kg	80	83	86	92	103
Article code	BP3508A000	BP3510A000	BP3512A000	BP3515A000	BP3520A000



PROFICOUPEVO TILE CUTTERS

- Solid aluminum base plate for reduced weight.
- Professional material guide, continuously adjustable.
- Diagonal cutting: fast because of the fit guide.
- Accuracy from the dual scales.
- Scratch-free breaking bracket and comfort handles.
- Fold-away supports on both sides.
- Maximum material thickness 15 mm.

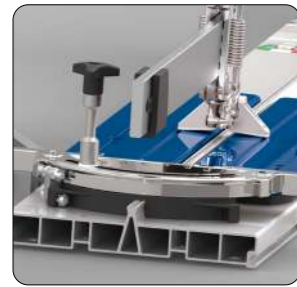

Diagonal cutting



Aluminum footplate for weight reduction



Springs for a clean cut

Type	Cutting length cm	Diagonal cm	Article code
Proficoupevo 63	63	44 x 44	BUEV606300
Proficoupevo 88	88	62 x 62	BUEV608800
Proficoupevo 103	103	72 x 72	BUEV601030
Proficoupevo 133	133	94 x 94	BUEV601330
Proficoupevo 163	163	115 x 115	BUEV601630
Proficoupevo cutting wheel	Ø 15 mm		BU49100000



SUPERPRO TILE CUTTERS

- Sprung platforms to guarantee a perfect cutting surface, even for large, hard tiles.
- Maximum material thickness 1.9 cm.



Type	Cutting length cm	Diagonal cm	Article code
Superpro 450	45	32 x 32	BU30450000
Superpro 600	60	42 x 42	BU30600000
Superpro 750	75	52 x 52	BU30750000
Superpro 900	90	62 x 62	BU30900000
Superpro cutting wheel	Ø 22 mm		BU49200000

TILE CUTTER TSP-60

- Extra support for large tiles.
- In a plastic case.
- Maximum material thickness 1.5 cm.

Type	Cutting length cm	Diagonal cm	Article code
TSP-60	60	40 x 40	BU10600000
TSP-60 cutting wheel	Ø 10 mm		BU49400000

EXCELLENT TILE CUTTER

- Tile cutting board with fold-away supporting frame, for working at the ideal height.
- With broad supporting foot and extra lateral supports.

Type	Cutting length cm	Diagonal cm	Article code
Excellent	60	40 x 40	BU50600000
Excellent cutting wheel	Ø 21 mm		BU49300000





Before



After



TILE LEVELLING SYSTEM

- For easy, fast and perfect installation of (large) tiles.
- Ideal for wall and floor tiles.
- The basic kit consists of 1 pair of clamp pliers, 100 strips and 100 clamps, delivered in a tub.

Description	Article code
Complete set	BTNSSET000

ACCESSORIES

Description	Article code
Pack of 100 strips	BTNS010000
Pack of 100 clamps	BTNS020000
Clamp pliers	BTNS030000



2 gears



In a solid plastic case



Non-slip handle with integrated switch

HAND-HELD MIXER

- For mixing tile glue, cement, paint, varnish, epoxy resin, etc.
- Very robust motor. 2 gears, electronically adjustable.
- M14 connector.
- In a plastic case.
- Including 14 cm stirring rod.

Technical data	1.600	1.900
Power kW (hp)	1.6 (2.2)	1.9 (2.6)
Voltage V	230	230
Weight kg	11	13
Article code	BUI0010000	BUI0020000

ACCESSORIES

Description	Article code
Stirring rod Ø 14 cm	BUI0010140
Stirring rod Ø 16 cm	BUI0010160





Forced action mixer



Can be filled easily

MIXER 50 SUPER

- For the perfect homogenous mix – for tile adhesive, cement, paint, varnish, epoxy resin, gravel floors etc.
- The thermal protection prevents motor overload.
- The mixer can be transported easily even when the tub is full.
- Can be dismantled into three pieces so that the mixer does not take much space when stored or transported.

Technical data	
Power kW (hp)	: 1.2 (1.6)
Voltage V	: 230
Tub volume, litres	: 65
Maximum mixing capacity kg	: 50
Weight kg	: 24
Article code	: BUI005S000
Description	Article code
Mortar tub 65 litres	XSM036-000



Conduit width 25 cm

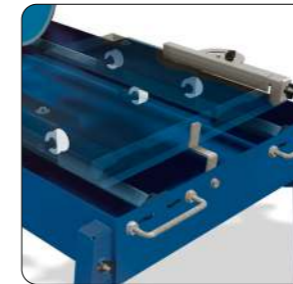

Saw trolley with 6 wheels



Patented water cooling



Adjustable height



Machine cover

S-COUP 350

- Universal stone saw machine for cutting all types of stone, concrete, tiles, roof tiles, etc.
- Large and robust saw trolley.
- Heavy-duty steel construction with powder-coated paint finish.

Technical data	
Power kW (hp)	: 2.2 (3.0)
Voltage V	: 230
Ø saw blade mm	: 350 x 25.40
Max. material thickness cm	: 11
Max. cutting length cm	: 80
Max. conduit width cm	: 25
Weight kg	: 67
Article code	: BEG3500000
Accessories	Article code
Machine cover S-coup	BTHOES0000

- UNIVERSAL p. 27
- CONCRETE p. 28
- BRICK p. 29
- TILES p. 30/31





X-COUP 350

- Universal stone sawing machine for cutting all types of stone, concrete, tiles, roof tiles etc.
- Adjustable by 45°.
- Foldable chassis.



Transit width 30.4 cm



Adjustable material guide



Easy to change blades



45° adjustable



Machine cover

Technical data	
Power kW (hp)	: 2.2 (3.0)
Voltage V	: 230
Ø saw blade mm	: 350 x 25.40
Max. material thickness cm	: 11
Max. material thickness cm (2 passes)	: 15.5
Max. cutting length cm	: 80
Weight kg	: 75
Article code	: BEX3500000
Accessoires	
Machine cover X-coup	BTHOES0000

- UNIVERSAL p. 27
- CONCRETE p. 28
- BRICK p. 29
- TILES p. 30/31

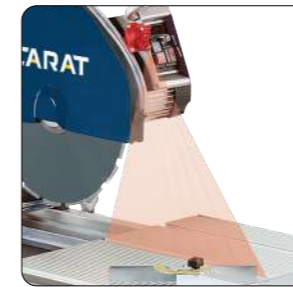

Laser ruler



Mitre cutting



Conduit width 28 cm



Adjustable material guide

T-3510 LASER

- Revolutionary stone saw machine with laser ruler.
- High-tech construction in aluminum and ABS with transport wheels.
- Up to 20% lighter than conventional machines.
- Also available with 400V motor.

Technical data	
Power kW (hp)	: 2.3 (3.0)
Ø saw blade mm	: 350 x 25.40
Max. material thickness cm	: 11
Max. material thickness cm (2 passes)	: 13
Max. cutting length cm	: 80
Weight kg	: 68
Transport dimensions L x W x H cm	: 120 x 80 x 81
Article code 230V	: BT3510L000
Article code 400V	: BT3510LWSK
Accessories	
Machine cover T-3510	BTHOES0000

- UNIVERSAL p. 27
- CONCRETE p. 28
- BRICK p. 29
- TILES p. 30/31





T-4010

- High-tech construction in aluminum and ABS with transport wheels.
- Up to 20% lighter than conventional machines.
- With adjustable material guide.
- Including wheels and laser.

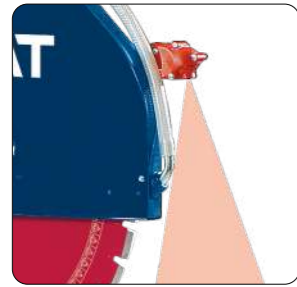

Laser ruler



Large cutting depth



Adjustable material guide

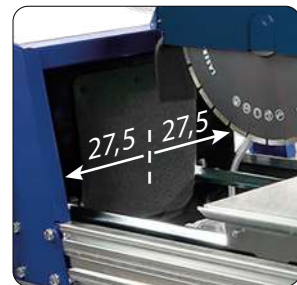

Maximum throughput width 55 cm

Technical data	
Power kW (hp)	: 2.8 (3.8)
Voltage V	: 230
Ø saw blade mm	: 400 x 25.40
Max. material thickness cm	: 13.5
Max. cutting length cm (45cm saw trolley)	: 80
Weight kg	: 73
Article code	: BT4010L000
Accessories	
Machine cover T-4010	Article code BTH0ES0000

- UNIVERSAL p. 27
- CONCRETE p. 28
- BRICK p. 29

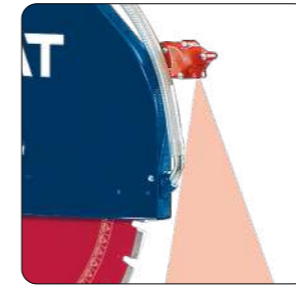

Laser ruler



Saw trolley with 6 wheels (with ball bearings)



Large cutting depth (T-6010)



Transit width from engine mount 29 cm

T-5010 and T-6010 LASER

- Revolutionary stone saw machine.
- Durable high-tech construction in aluminum and ABS.
- Huge weight saving compared to conventional machines.
- Also available with 230V motor.

Technical data		T-5010	T-6010
Power kW (hp)	230V	3.5 (4.5)	3.5 (4.5)
	400V	4.0 (5.5)	4.0 (5.5)
Ø saw blade mm		500 x 25.40	600 x 25.40
Max. material thickness cm		17	22
Max. material thickness (2 passes) cm		23	28
Max. cutting length cm		75	75
Weight kg		80	80
Transport dimensions			
L x W x H cm		120 x 80 x 103	120 x 80 x 110
Article code	230V	BT5010L230	BT6010L230
Article code	400V	BT5010L000	BT6010L000

- UNIVERSAL p. 27
- CONCRETE p. 28
- BRICK p. 29



T-6010



T-7010 and P-7010 LASER

- For cutting large sand-lime blocks and bricks.
- Durable high-tech construction in aluminum and ABS.
- Including variable material guide.

Technical data	T-7010	P-7010
Power kW (hp)	4.0 (5.5)	4.0 (5.5)
Voltage V	400	400
Ø saw blade mm	700 x 25.40	700 x 25.40
Max. material thickness cm	27	27
Max. material thickness (2 passes) cm	34	34
Max. cutting length cm	55	62
Weight kg	95	117
Article code	BT70100000	BP70100000

Blades for this machine	Article code
Concrete	CNC7004000
Brick	CNA7004000
Universal	CNE7004000



Large cutting depth



Saw trolley with 6 wheels (with ball bearings)



Wheels



Laser ruler



T-7010

P-7010





W-5421 WALL SAW MACHINE

for cutting in concrete up to 21 cm

- Operates on normal main electricity (230V).
- With PRCD switch.
- Including guide rails, filling plates, saw blades \varnothing 350, 450 and 540 mm and transport cases.



Machine on rail



Complete set

Technical data	
Power kW (hp)	: 2.2 (2.8)
Voltage V	: 230
Max. \varnothing saw blade mm	: 540 x 30.00
Max. material thickness cm	: 21
Weight kg	: 4.6
Article code	: MZW5421SET
Accessories for this machine	
Guide rail 1.3 m	MZW5421130
Guide rail 2.3 m	MZW5421230
Concrete blades for this machine	
\varnothing 350 x 30.00 mm	CWB3505000
\varnothing 450 x 30.00 mm	CWB4505000
\varnothing 540 x 30.00 mm	CWB5405000



Lightweight, strong magnesium cover



LED indicator that indicates when the machine is overloaded



Dust extraction modules

DS-3500 and DS-4000

- Lightweight, strong magnesium cover.
- LED indicator that indicates when the machine is overloaded.
- Splash guard and guide rollers are removable without tools.
- Integrated water supply.
- PRCD switch.
- The DS-4000 can be fitted with a flush cut flange, making it possible to flush cut.

Technical data	DS-3500	DS-4000
Power kW (hp)	: 2.8 (3.8)	3.2 (4.4)
Voltage V	: 230	230
RPM	: 4.500	3.900
Max. \varnothing saw blade mm	: 350 x 25.40	400 x 25.40
Max. cutting depth cm	: 12.5	15
Weight kg	: 7.9	9.6
Article code	: MZDS350000	MZDS400000

Accessories	Article code
Dust skid DS-3500	MZDSSK3500
Dust skid DS-4000	MZDSSK4000
Flush cut cover DS-4000	MZDSFS4100
Flush cut kit DS-4000	MZDSFS4200

Flush cut blade	\varnothing mm	Arbor hole \varnothing mm	Article code
Concrete CS MASTER	400	25.40	CSM4004BF0

- UNIVERSAL p. 21
- CONCRETE p. 23/24
- BRICK p. 25
- TILES p. 26



DS-3500

DS-4000



Cutting depth 22 cm

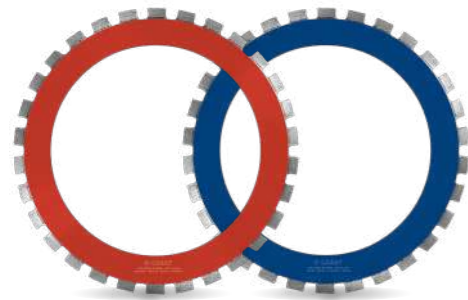

Easy to change ring blades

**RS-3300**

- Integrated water supply.
- Adjust the blade with one rotary knob.
- LED indicator shows the load for cutting with maximum efficiency.
- Guide wheels with three grooves for precise and centralised use of the saw.
- The blade can be replaced quickly without dismantling the protective cover.

Technical data

Power kW (hp)	: 3.2 (4.4)
Voltage V	: 230
RPM	: 2.850
Ø saw blade mm	: 330
Max. cutting depth cm	: 22
Weight kg	: 12.9
Article code	: MZRS330000

Accessories	Ø mm	Article code
Ringsaw abrasive*	330	CRSA330000
Ringsaw concrete*	330	CRSC330000
Drive wheel	22	CRSDW10000

* Ringsaw is always supplied with a drive wheel.

**EASYCOUPNEXT 350**

- The ideal cut-off machine.
- For both wet and dry use.
- Dust extraction to ensure dust-free working.

Technical data

Power kW (hp)	: 2.2 (3.0)
Voltage V	: 230
Ø saw blade mm	: 350 x 25.40
Max. material thickness cm	: 11
Max. cutting length cm	: 24
Weight kg	: 38
Article code	: BUC350N000

UNIVERSAL	p. 27
CONCRETE	p. 28
BRICK	p. 29



Sturdy sawing table with bearings

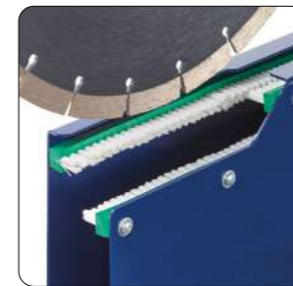

Brushes to minimise dust



Durable and sturdy construction





SL-1253N DUSTEC®

- Minimum dust generation because of the special saw cover.
- With a spindle lock so that the blades are easy to swap.
- Including transport case and 2 diamond blades, type CE Master universal Ø 125 mm.

Technical data

Power kW (hp)	: 1.7 (2.3)
Voltage V	: 230
Ø saw blades mm	: 125 x 22.23
Max. cutting depth cm	: 2.7
Cutting width cm	: 1.3 - 4
Weight kg	: 4.8
Article code	: MZSL1253NS



Adjustable cutting width



Maximum cutting depth



Dust extraction



Adjustable cutting depth



UNIVERSAL p. 4-8

CONCRETE p. 10/11

BRICK p. 12

SL-1255 DUSTEC®

A light and convenient wall chaser with a maximum depth of 40 mm and cutting width up to 35 mm. Features outstanding dust control.

- Hall Effect Type Switch is impervious to dust or water.
- Large switch for holding in various positions.
- Smart Electronic Control for constant speed, soft start, overload and thermal protection.
- Cutting depth adjustment.
- Quick-opening blade guard.
- Including transport case and 2 diamond blades type CE Master universal Ø 125 mm.

Technical data

Power kW (hp)	: 1.8 (2.5)
Voltage V	: 230
Ø blades mm	: 125 x 22.23
Max. cutting depth cm	: 4
Cutting width cm	: 3.5
Weight kg	: 4.7
Article code	: MZSLB1255S



Quick change system



Led overload indicator



Simple changing blades

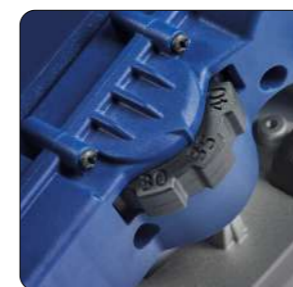

Easy depth adjustment



UNIVERSAL p. 4-8

CONCRETE p. 10/11

BRICK p. 12



SL-1502 DUSTEC®

- Extremely deep cuts.
- Minimum dust generation because of the special saw cover.
- Including transport case and 2 diamond blades, type CE Master universal Ø 150 mm.
- For bricks and concrete.

SL-1506X DUSTEC®

- Cutting out milled pipes is no longer necessary.
- Minimum dust generation because of the special saw cover.
- Including transport case and 6 diamond blades, type universal Ø 150 mm.
- Only suitable for brick and limestone.

Technical data	SL-1502	SL-1506X
Power kW (hp)	2.0 (2.7)	2.0 (2.7)
Voltage V	230	230
Saw blades Ø 150 x 22.23 mm	2	6
Max. cutting depth cm	5	5
Cutting width cm	0.7 - 5	0.7 - 5
Cutting width fixed with 6 blades cm		2.1
Weight kg	6.5	6.5
Article code	MZSLB1502S	MZSLB1506X

- UNIVERSAL p. 4-8
- CONCRETE p. 10/11
- BRICK p. 12



Laser ruler



Maximum cutting depth

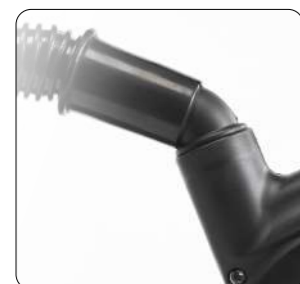

Dust extraction



Adjustable cutting width 0.7-5 cm



Also available with 6 blades



SL-1506X

SL-1502



Quick change system



LED overload indicator



Easy depth adjustment



Guide rail

SL-1505 DUSTEC®

- Powerful wall chaser (2500W).
- 6 wheels for maximum support during cutting.
- Motor equipped with advanced protection, including soft start, overload and thermal safety.
- The optional railsystem offers maximum comfort during cutting.
- Including transport trolley and 2 diamond blades type CE Master universal Ø 150 mm.

Technical data	
Power kW (hp)	: 2.5 (3.4)
Voltage V	: 230
Ø blades mm	: 150 x 22.23
Max. cutting depth cm	: 5
Cutting width cm	: 0.7 - 4.7
Weight kg	: 7.2
Article code	: MZSLB1505S

Accessories	Article code
Carat guide rail 140 cm	MZSLB14000
Carat floor-sealing clamp set	MZSLB10000

- UNIVERSAL p. 4-8
- CONCRETE p. 10/11
- BRICK p. 12





Full view of the work



For tuck point cutting up to 8 cm thickness



Dust extraction

JC-1253N DUSTEC®

- Minimum dust generation because of the unique sawing cover with a brush.
- With a spindle lock so that the blades are easy to swap.
- Developed in cooperation with TNO.
- Including transport case and a flexible 1-meter hose to fit almost all standard vacuum cleaners.

Technical data

Power kW (hp)	: 1.7 (2.3)
Voltage V	: 230
Ø tuck point blade mm	: 125 x 22.23
Weight kg	: 4.6
Article code	: MZJC1253N0

SOFT JOINT p. 34

HARD JOINT p. 35



Dust extraction



Brushes in the cover



Lets you work right up against the wall

BS-1253N DUSTEC®

- Powerful 1700W engine.
- For dust-free removal of formwork and concrete residues and levelling floors and walls.
- With a spindle lock so that the grinding heads are easy to swap.
- Removing a layer results in a well-finished surface, ready for further processing.
- Including transport case.

Technical data

Power kW (hp)	: 1.7 (2.3)
Voltage V	: 230
Ø grinder head mm	: 125
Weight kg	: 3.3
Article code	: MZBS1253N0

Article code

Dust cover brush set	: XAM-6C57006C
----------------------	----------------

CONCRETE p. 38-43

BRICK p. 38





PRO GRINDER 125 DUSTEC®

A 125 mm high endurance, angle-type concrete grinder with 2000W motor. Excellent dust control for renovation tasks. Use different diamond cup wheels or PCD cup wheels for various substrates.

- With electronic overload and thermal protection.
- Constant speed electronics for an even finish.
- Variable speed for different applications.
- LED load indicator allows operator to grind at maximum efficiency.
- Anti-restart hall effect-type switch is impervious to dust.
- Adjustable ergonomic front handle.
- Dust control skirt with spring suspension and replaceable bristles effectively contains dust.
- Tool-free sliding cover for edge grinding.
- Including transport case.

Technical data

Power kW (hp)	: 2,0 (2,7)
Voltage V	: 230
Ø grinder head mm	: 125 X 22,23
Weight kg	: 4.7
Article code	: MZBS125400
Article code	
Brush small	XAGBS1008150
Brush big	XAGBS1008550



Replaceable brushes



Adjustable handle



Work up to the wall

CONCRETE p. 38-43
BRICK p. 38

TWOGRIP CONCRETE GRINDERS DUSTEC®

- Electronically adjustable speed for different conditions.
- High throughput thanks to 2200W motor.
- Particularly quiet run.
- Softstart and overload protection.
- Effective extraction and automatic sealing by brush ring with resilient suspension.
- Includes transport case.

Technical data	TwoGrip 125	TwoGrip 180
Power kW (hp)	2.2 (3.0)	2.2 (3.0)
Voltage V	230	230
Ø grinding cup mm excl.	125 X 22.23	180 x 22.23
Weight kg	5.8	5.9
Article code	MZBS125500	MZBS180500



Adjustable speed



Work up to the wall



TwoGrip Trolley

TWOGRIP TROLLEY

This handy trolley makes working even easier. Attach the concrete grinder in this trolley and you can grind the floor while standing.

- 3 meter integrated extension cord, switch and wall socket.
- Adjustable in height.
- Pivot wheel for optimum manoeuvrability.

Article code : MZBSTRL000

CONCRETE p. 38-43
BRICK p. 38



TwoGrip 125

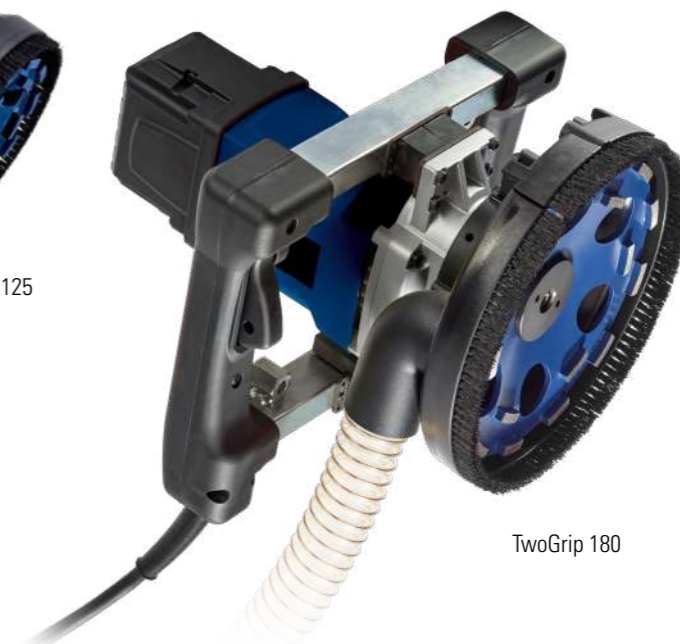

TwoGrip 180



PRO GRINDER 180 DUSTEC®

High Endurance Pro Grinder

- 180mm, high endurance concrete grinder with excellent dust control.
- Variable speed for different applications.
- LED Indicator for optimizing grinding efficiency with overload and overheat warning.
- Adjustable ergonomic front handle allows clearance for edge grinding.
- Lock-On Hall Effect switch is completely waterproof and dustproof. Includes anti-restart function to protect operator in the event of interrupted power supply.
- Robust 2000W universal motor with constant speed electronics for an even finish.
- Half-Moon door for grinding up to the edge.
- Including transport case.



Adjustable handle



Replaceable brushes



Work up to the wall

Technical data	
Power kW (hp)	: 2,0 (2,7)
Voltage V	: 230
Ø grinder head mm	: 180 X 22.23
Weight kg	: 5,0
Article code	: MZBS180400
Article code	
Brush small	XAGBS30007
Brush big	XAGBS30009

- CONCRETE p. 38-43
- BRICK p. 38



The height of the push bracket is adjustable



Detachable 20-litre water tank

VZ-500

- The cutting blade can be mounted on the right-hand side.
- Cutting depth indicator.
- Cyclone air filter, specially for dry cutting.
- High quality bearings.
- With type GX390 Honda motor.

Technical data	
Motor	: Honda, petrol
Power kW (hp)	: 9.65 (13.0)
Max. Ø saw blade	: 500 x 25.40
Max. cutting depth cm	: 18
Weight kg	: 106
Article code	: RVZ5000000

- CONCRETE p. 23
- BRICK p. 25





DIAMOND DRILLS

	Page
Choosing the right diamond drill	81
Diamond drills for concrete and hard stone materials	82
Choosing the right adapter for wet core drilling	87
Accessories for diamond drills	88
Choosing the right adapter for dry drilling	90
Diamond drills for wall sockets	91
Diamond drills and accessories for brick and abrasive stone materials	92
Diamond drills for tiles and natural stone	98
TILEPROCESSING	
Diamond mills	104
Diamond sanding and polishing pads	105

Connect directly to a Carat drill machine with an M30 connection!

- 1 connection, all Ø M30.
- Connect directly onto the drill machine.
- Clear UV print for faster, correct choice.
- Less weight.
- Makes your work more compact.
- Centring pin as an accessory.



Two key questions when choosing the right diamond drill:

1

What material is it for?

The Carat diamond drill range has three categories:

**For use with water cooling:
CONCRETE, HARD STONE MATERIALS**

Specially developed for drilling in reinforced or normal concrete and all other hard to very hard stone materials.



**For use without water cooling:
CONCRETE, HARD STONE MATERIALS**

Specially developed for dry drilling in (reinforced) concrete.



**For use without water cooling:
BRICK, ABRASIVE STONE MATERIALS**

Specially developed for drilling in all abrasive, sandy stone types.



2

Which quality?

Whether you choose Carat Master or Classic drills, you will always be choosing the best quality. Drilling speed, performance... Everything has been matched up perfectly.



i

Features of diamond drills

LASER Laser-welded: The segments are attached to the drill using lasers, providing a 100% guarantee against weld breakage.

FASTIP Fastip.

TURBO-TWISTED TT segments: Segments with a revolutionary, serrated point. They guarantee a quick first cut into the material being drilled.

DUSTEC Dustec® variant with slots in the flange for use with Dustec® dust extraction.

NASTRUC Nastroc®.

LASER CONCRETE MASTER

• Other diameters and lengths are available upon request.



Ø mm	Length mm	Article code
14	200	EM01420050
14	300	EM01430050
16	200	EM01620050
16	300	EM01630050
18	300	EM01830050
20	300	EM02030050
22	300	EM02230050
24	300	EM02430050
25	300	EM02530050
26	300	EM02630050
28	300	EM02830050
29	300	EM02930050
31	300	EM03130050
31	400	EM03140050
36	300	EM03630050
36	400	EM03640050
41	300	EM04130050
41	400	EM04140050
46	300	EM04630050
46	400	EM04640050
51	300	EM05130050
51	400	EM05140050
51	500	EM05150050
56	300	EM05630050
56	400	EM05640050
61	300	EM06130050
61	400	EM06140050
66	300	EM06630050
66	400	EM06640050
71	300	EM07130050
71	400	EM07140050
76	300	EM07630050
76	400	EM07640050
81	70	EM08107050
81	300	EM08130050
81	400	EM08140050
86	300	EM08630050
86	400	EM08640050



LASER CONCRETE MASTER

Ø mm	Length mm	Article code
91	300	EM09130050
91	400	EM09140050
101	300	EM10130050
101	400	EM10140050
111	300	EM11130050
111	400	EM11140050
121	300	EM12130050
121	400	EM12140050
126	300	EM12630050
126	400	EM12640050
131	300	EM13130050
131	400	EM13140050
141	400	EM14140050
151	400	EM15140050
161	400	EM16140050
166	400	EM16640050
171	400	EM17140050
181	400	EM18140050
201	400	EM20140050



DRILLSET M30 MASTER

Content	
Ø mm	: 31, 51, 81 en 131
Length mm	: 400
Connection	: M30
Article code	: EMSET010NL





LASER CONCRETE CLASSIC+

• Other diameters and lengths are available upon request.

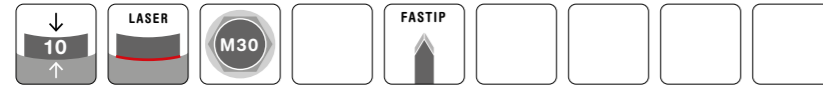

Ø mm	Length mm	Article code
18	400	EC01840050
20	400	EC02040050
25	400	EC02540050
31	400	EC03140050
36	400	EC03640050
41	400	EC04140050
51	400	EC05140050
61	400	EC06140050
71	400	EC07140050
81	400	EC08140050
91	400	EC09140050
101	400	EC10140050
111	400	EC11140050
131	400	EC13140050
151	400	EC15140050
161	400	EC16140050



CONCRETE, 5/4" UNC connector

• Silver soldered.

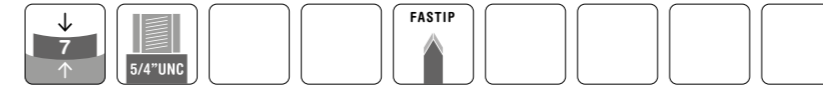

Ø mm	Length mm	Article code
220	400	EP22040020
250	400	EP25040020
275	400	EP27540020
300	400	EP30040020
350	400	EP35040020



Drillset M30 CLASSIC+

Content	
Ø mm	: 31, 51, 81 en 131
Length mm	: 400
Connection	: M30
Article code	: ECSET010NL





DIAMOND DRILLS FOR CONCRETE AND HARD STONE MATERIALS

LASER CONCRETE DRY **DRY BETON**

With Carat DRY drilling, you can drill simply into hollow-core slabs and reinforced concrete using diamond drills combined with a soft hammer function and dust extraction.

- The drills are have a spiral groove to ensure better dust extraction and cooling.
- Very stable drilling.
- Positioned diamond turbo segments (Diatex® technology) for 100% performance.

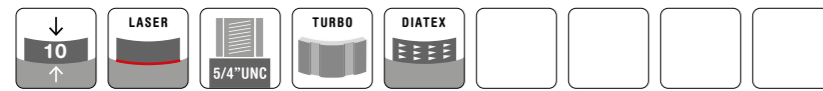

Ø mm	Length mm	Article code
52	300	ED05230020
57	300	ED05730020
62	300	ED06230020
68	300	ED06830020
72	300	ED07230020
82	60	ED08206020
82	300	ED08230020
92	300	ED09230020
102	300	ED10230020
112	300	ED11230020
122	300	ED12230020
127	300	ED12730020
132	300	ED13230020
142	300	ED14230020
152	300	ED15230020
162	300	ED16230020



DRILL SET CONCRETE DRY **DRY BETON**

Content	
Ø mm	: 52, 82, 112 en 132
Length mm	: 300
Connection	: 5/4"UNC
Article code	: EDSET04000



DIAMOND DRILLS FOR CONCRETE AND HARD STONE MATERIALS

Drill machine with M30 connection

- BC30100000 → CARAT WET CORE DRILLING 1/2" G CONNECTION
- BC30200000 → CARAT WET CORE DRILLING 5/4" UNC CONNECTION
- BC30300000 → CARAT WET CORE DRILLING M30 CONNECTION
- BC30400000 → CARAT WET CORE DRILLING M16 CONNECTION

Drill machine with 1/2" G connection

- ES00400000 → CARAT WET CORE DRILLING M16 CONNECTION
- ES00500000 → CARAT WET CORE DRILLING M30 CONNECTION

Drill machine with 5/4" UNC connection

- ES00410000 → CARAT WET CORE DRILLING M16 CONNECTION
- ES00510000 → CARAT WET CORE DRILLING M30 CONNECTION
- ES00510000 → CARAT NASTROC DRY DRILLING M30 CONNECTION

Drill machine with NASTROC connection

- ANA040000 → CARAT WET CORE DRILLING M16 CONNECTION
- ANA050000 → CARAT WET CORE DRILLING M30 CONNECTION
- ANA050000 → CARAT NASTROC DRY DRILLING M30 CONNECTION



M30 EXTERNAL SCREW THREADED ADAPTERS

Description	Article code
1/2"G	ES00500000
5/4"UNC	ES00510000
NT-NASTROC®	ANA0500000
SDS-DI - 1/2"G (internal)	ES00560000
M16 (internal)	HDND001000

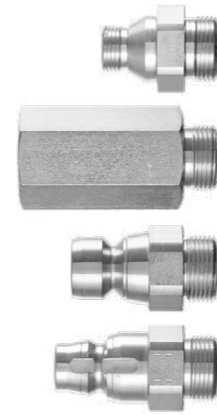

M30 INTERNAL SCREW THREADED ADAPTERS

Description	Article code
1/2"G	BC30100000
5/4"UNC	BC30200000
M30	BC30300000
M16 (external)	BC30400000



M16 EXTERNAL SCREW THREADED ADAPTERS

Description	Article code
1/2"G	ES00400000
5/4"UNC	ES00410000
NT-NASTROC®	ANA0400000
SDS-DI	ES00460000

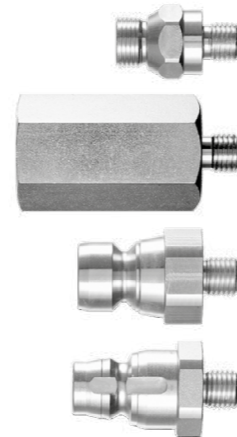

EXTENSIONS

- When using 1/2"G extensions: minimum drill diameter 31 mm.
- When using 5/4"G extensions: minimum drill diameter 51 mm.

Length mm	Machine connection	Article code
100	1/2"G	BC21100000
200	1/2"G	BC21200000
300	1/2"G	BC21000000
100	5/4"UNC	BC22010000
200	5/4"UNC	BC22020000
300	5/4"UNC	BC22000000
400	5/4"UNC	BC22040000



EXTENSIONS for M30 diamond drills

- When using M30 extensions: minimum drill diameter 41 mm.

Length mm	Connection	Article code
150	M30	BCN1505000
300	M30	BCN3005000

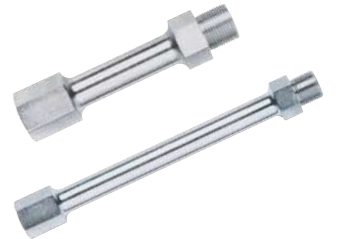

EXTENSIONS for M16 diamond drills

- For use with 5/8"x 16UNF.
- Extensions fit on each other.

Length mm	Connection	Article code
200	5/8"x 16UNF	HDC0032000
300	5/8"x 16UNF	HDC0033000





Drill machine with 13mm drill chuck

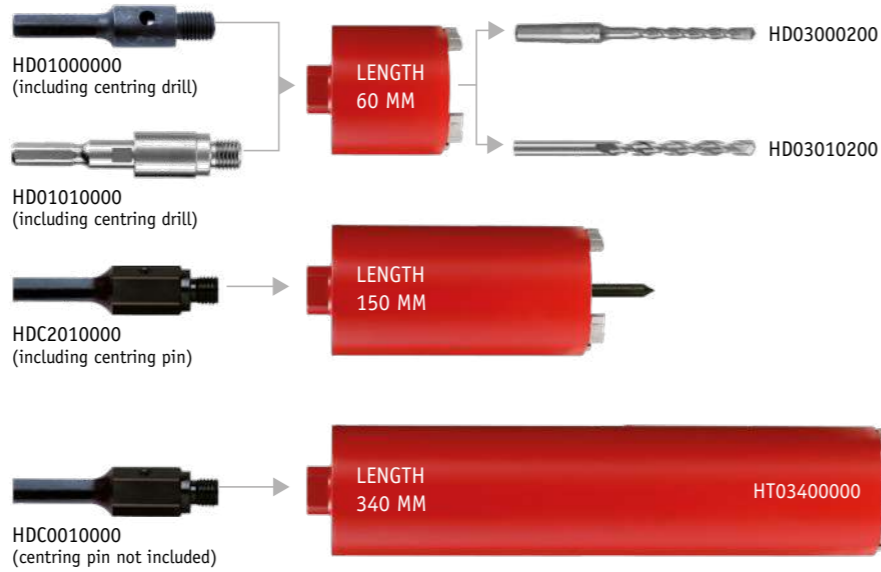

Drill machine with SDS drill chuck



Not suitable for SDS-Max

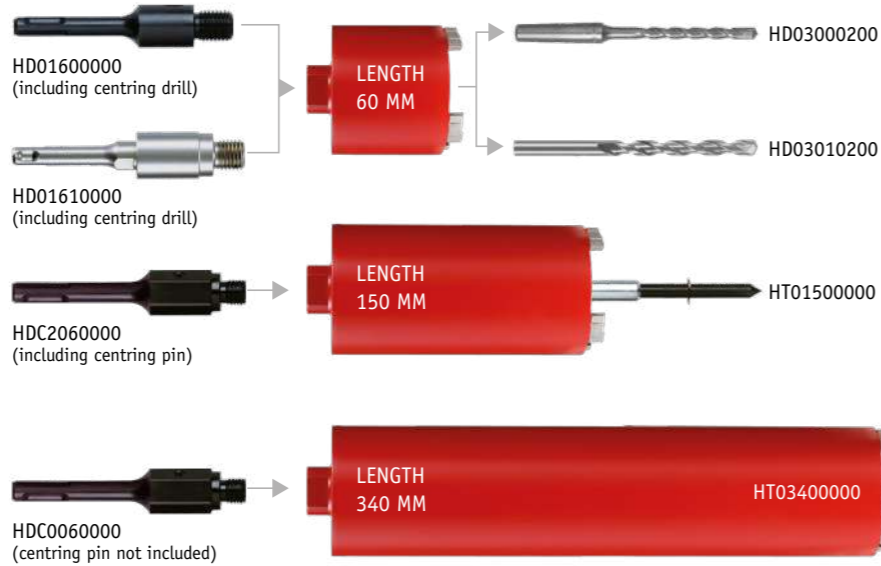

Drill machine with 5/8"x16UNF spindle

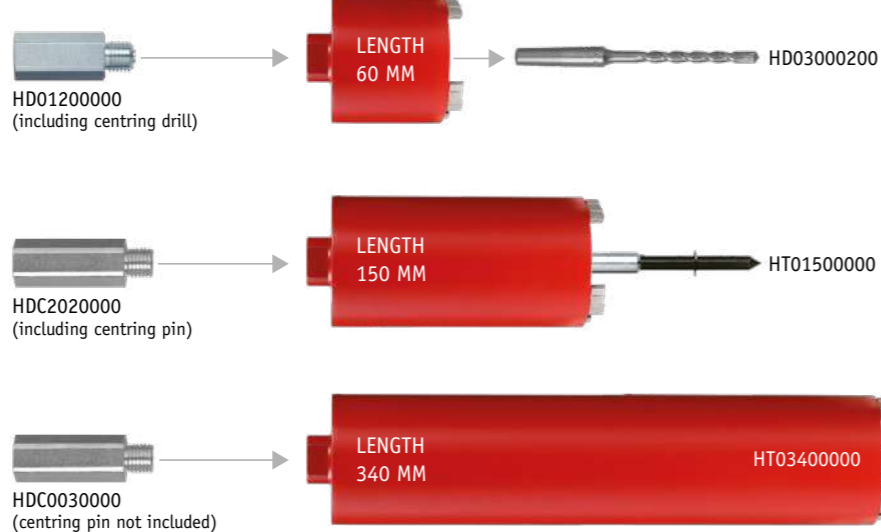

CARAT BOX DRILLS, Ø 82 mm

- M16 screw thread for use on mounting spindle and Dustec® drill chucks.
- Usable drill length: 60 mm.
- Laser-welded, 100% guarantee against weld breakage.



BOX DRILL DUSTEC® SUPER

Number of TT-segments	Segment height	Article code
5	9.5 mm	HTS082604S

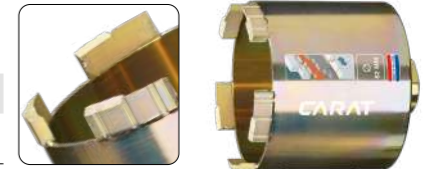

BOX DRILL DUSTEC® PREMIUM

Number of TT-segments	Segment height	Article code
4	9.5 mm	HTS082604P

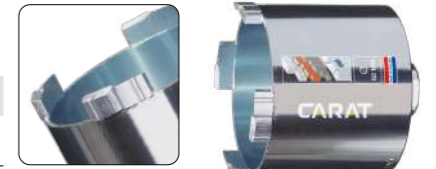

BOX DRILL DUSTEC® ECONOMY

Number of segments	Segment height	Article code
4	7 mm	HTS068604E
4	7 mm	HTS082604E



BOX DRILL NASTROC®, M30

Number of TT-segments	Segment height	Article code
4	9.5 mm	HDN0820605



BOX DRILL BRILLIANT

- 20 special TT grip segments for super-fast drilling and for very easy first cuts.
- Less friction because of the thinner drill tube.

Number of TT-segments	Segment height	Article code
20	9 mm	HTB0826040

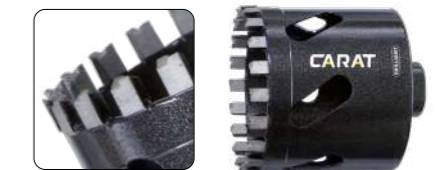

DRY DRILLING, length 60 mm x M16

- With slots in the side.

Ø mm	Number of segments	Article code
32	3	HDND032604
42	3	HDND042604
52	3	HDND052604
62	3	HDND062604

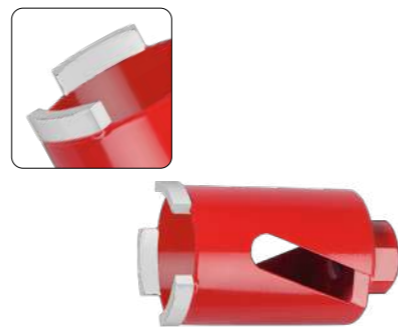

DUSTEC® DRY DRILLING, length 60 mm x M16

- With slots in the flange for use with Dustec® dust extraction.

Ø mm	Number of segments	Article code
68	3	HTS0686040
72	4	HTS0726040
76	4	HTS0766040
87	4	HTS0876040
92	4	HTS0926040
102	5	HTS1026040
112	5	HTS1126040
122	6	HTS1226040
132	6	HTS1326040



MOUNTING SPINDLES M16

with centring drill for dry drilling, length 60 mm

FOR 13 MM DRILL CHUCK

Description	Article code
With ejector pin	HD01000000
With quick-change system	HD01010000

FOR SDS PLUS SYSTEM

Description	Article code
With ejector pin	HD01600000
With quick-change system	HD01610000



CENTRING DRILLS packed per 2

Description	Article code
Ø 7 mm for use with ejector pin	HD03000200
Ø 8 mm for use with quick-change system	HD03010200

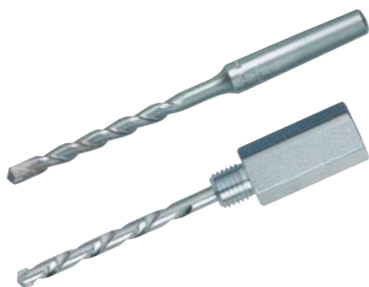

DRY CORE DRILLS, length 150 mm x M16

- With Fastip segments.
- With slots in the side.

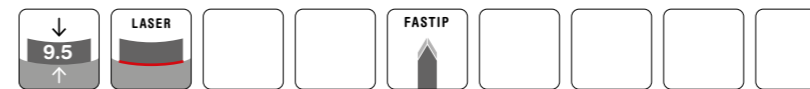

Ø mm	Number of segments	Article code
32	3	HDC0321504
42	3	HDC0421504
52	3	HDC0521504
62	3	HDC0621504



DUSTEC® DRY CORE DRILLS, length 150 mm x M16

- With slots in the flange for use with Dustec® dust extraction.
- With turbo-twisted segments.



Ø mm	Number of segments	Article code
68	3	HTM0681504
72	4	HTM0721504
82	4	HTM0821504
92	4	HTM0921504
102	5	HTM1021504
112	5	HTM1121504
122	6	HTM1221504
132	6	HTM1321504
142	6	HTM1421504
152	6	HTM1521504
162	7	HTM1621504



MOUNTING SPINDLES M16

with centring pin for dry drilling, length 150 mm

Description	Article code
For 13 mm drill chuck	HDC2010000
For SDS plus drill chuck	HDC2060000
For 5/8" x 16UNF spindle	HDC2020000



DUSTEC® DRY CORE DRILLS, length 340 mm x M16

- With slots in the flange for use with Dustec® dust extraction.



Ø mm	Number of segments	Article code
32	3	HTL0323404
42	3	HTL0423404
52	3	HTL0523404
62	3	HTL0623404
68	3	HTL0683404
72	4	HTL0723404
82	4	HTL0823404
92	4	HTL0923404
102	5	HTL1023404
112	5	HTL1123404
122	6	HTL1223404
132	6	HTL1323404
142	6	HTL1423404
152	6	HTL1523404
162	7	HTL1623404

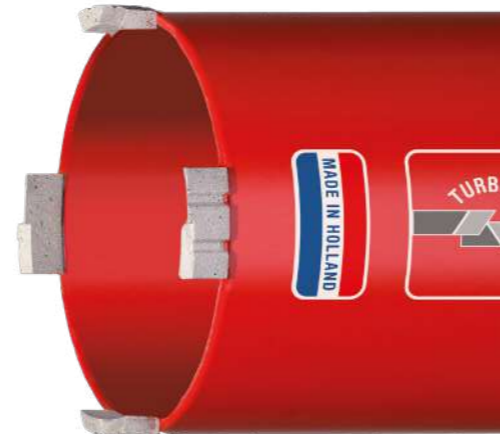

DUSTEC® DRILL CHUCK

Machine connection	Article code
5/8" x 16UNF	DPB0310000
M18 x 2.5	DPB0320000
1/2" x 20UNF	DPB0330000
13 mm drill chuck	DPB0340000
SDS plus	DPB0350000
M16 x 2.0	DPB0360000
1/2"G	DPB0370000
M16 + hexagon + SDS spindle + ctr.pin	DPB0380000



DUSTEC® CENTRING PINS

Length mm	Article code
60	HT00600000
150	HT01500000
340	HT03400000



ADAPTERS FOR DUSTEC® DRILL CHUCK

Machine connection	Article code
Hexagon - 5/8" x 16UNF	HTZZ020000
SDS - 5/8" x 16UNF	HTZZ060000



NASTROC® DRY DRILLS, length 300 mm x M30

- To be combined with the NASTROC® quick-change system and A-2031/A-2032 diamond drills, for use with dust extraction.



Ø mm	Number of segments	Article code
32	3	HDN0323005
42	3	HDN0423005
52	3	HDN0523005
62	3	HDN0623005
72	4	HDN0723005
82	4	HDN0823005
92	4	HDN0923005
102	4	HDN1023005
112	4	HDN1123005
122	6	HDN1223005
132	6	HDN1323005
142	6	HDN1423005
152	6	HDN1523005
162	7	HDN1623005
172	7	HDN1723005

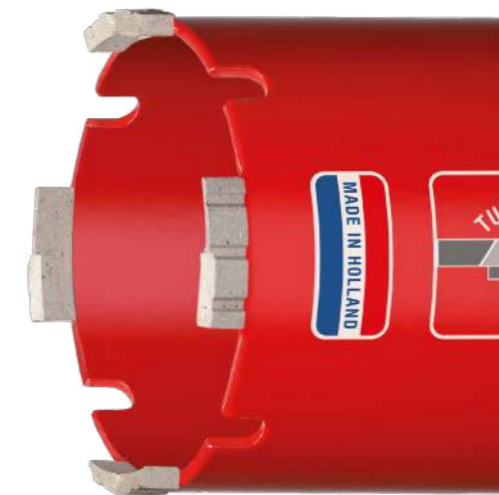

SUPPORT DISCS for DUSTEC® and NASTROC® centring pins

For diamond drill Ø mm	Article code
32	HDC3032000
42	HDC3042000
52	HDC3052000
62	HDC3062000
68	HDC3068000
72	HDC3072000
82	HDC3082000
92	HDC3092000
102	HDC3102000
112	HDC3112000
122	HDC3122000
132	HDC3132000
142	HDC3142000
152	HDC3152000
162	HDC3162000





M30 ADAPTER for Nastroc® diamond drills

Description	Article code
M30 Nastroc®	ANA0500000

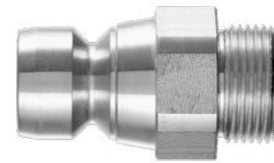

CENTRING PINS for diamond drills

For drills with length (mm)	Article code
300	HDN0010000
400	HDN0011000
300 Nastroc®	HDN0010NAS



EXTENSIONS for NASTROC® M30 diamond drills

- When using M30 extensions: minimum drill diameter 41 mm.

Length mm	Connection	Article code
150	M30	BCN1505000
300	M30	BCN3005000



DUSTEC® DIAMOND DRILL KIT for ceramic and sand-lime bricks

This set has been specially developed for professional installers.

The set consists of:

3 diamond drills (Ø 82x60 mm, 132x340 mm and 162x340 mm), Dustec® dust extraction, mounting spindles for Ø 13 mm chuck or SDS connector, centring pins with support discs; the entire set is packed in a transport case.

Description	Article code
Complete set	HTESET0300



DIAMOND DRILL KIT for brick and sand-lime bricks

This set of 5 diamond drills (Ø 32, 52, 82, 112 and 132 mm) lets you drill the most common types of holes easily. It can be mounted simply on drill motors with a 13 mm or SDS drill chuck.

The usable drilling length of 150 mm can be extended to 300 mm using the enclosed extensions. Packed in a transport case.

Description	Article code
Complete set	HTESET0000

DIAMOND DRILLS

Ø mm	Number of segments	Article code
32	3	HTE0321504
52	3	HTE0521504
82	4	HTE0821504
112	5	HTE1121504
132	6	HTE1321504



ACCESSORIES

Description	Article code
Extension 245 mm, M16 x hexagon	HD01000245
Extension 245 mm, M16 x SDS plus	HD02600245
Adapter M16 x hexagon	HD02000000
Adapter M16 x SDS-plus	HD02600000
Centre drill	HD03000245





DIAMOND DRILLS FOR TILES AND STONE

DIAMOND DRILL SET

for use with water cooling on cordless drills

- Set of 6 diamond drills, Ø 6-8-10-12-25-36 mm, centring aid and water rinse head. Drills fitted with 1/2" G connection.
- Delivered in a transport case.

Description	Article code
Complete set	ETSET04000



DIAMOND DRILLS **MASTER+**

Ø mm	Drilling depth mm	Article code
6	60	ET00607010
8	60	ET00807010
10	60	ET01007010
12	60	ET01207010
14	60	ET01407010
15	60	ET01507010
16	60	ET01607010
18	60	ET01807010
20	60	ET02007010
25	60	ET02507010
32	60	ET03207010
36	60	ET03607010
41	60	ET04107010
51	60	ET05107010
56	60	ET05607010
61	60	ET06107010
66	60	ET06607010
72	60	ET07207010
81	60	ET08107010



DIAMOND DRILLS FOR TILES AND STONE



DIAMOND DRILL SET

for wet use on (cordless) drills

- For tiles and nature stone.
- 4 diamond drills Ø 6-8-10-12 mm.
- Water rinse head and centring aid.

Description	Article code
Complete set	ETCSET0100



DIAMOND DRILLS **CLASSIC+**

Ø mm	Drilling depth mm	Article code
6	60	ETC0060000
8	60	ETC0080000
10	60	ETC0100000
12	60	ETC0120000



ACCESSORIES

Description	Article code
Centring aid, stainless steel	BCH0110000
Water rinse head	BB00BK4000
Core remover	BKV4000000





DIAMOND DRILLS FOR TILES AND STONE

DIAMOND DRILL SET

for wet use on (cordless) drills

- 10 diamond drills Ø 8-18-22-25-32-35-38-50-60-73 mm.
- Centring aid Ø 4-5-6-8-10-12-14 mm.
- Adjustable drill guide with suction cup Ø 6 to 83 mm.
- Cooling system 1.25 litres.
- Tile file for accurate finishing.

Description	Article code
Complete set	ETNSET0100

DIAMOND DRILLS

- Loose drills, packed as a set of 2 pieces.

Ø mm	Drilling depth mm	Article code
6	30	ETN0060000
8	30	ETN0080000
10	30	ETN0100000
12	30	ETN0120000
18	30	ETN0180000
22	30	ETN0220000
25	30	ETN0250000
32	30	ETN0320000
35	30	ETN0350000
38	30	ETN0380000
40	30	ETN0400000
50	30	ETN0500000
60	30	ETN0600000
73	30	ETN0730000
110	30	ETN1100000

ACCESSORIES

Description	Article code
Universal centring aid for up to Ø 73mm	ETNCA01000
Centring aid Ø 4-5-6-8-10-12-14mm	ETNCA02000
Cooling system	ETNCA03000



ETNCA01000



ETNCA02000



DIAMOND DRILLS FOR TILES AND STONE



DIAMOND DRILL SET

for dry use on (cordless) drills

- Ø 6-8-10-12 mm, centring aid and dust extraction.
- Drills equipped with hex socket for optimum grip in the drill bit.
- Provided with wax for good lubrication.
- Supplied in transport case.

Description	Article code
Complete set	ETDSET0200



DIAMOND DRILLS **MASTER**

Ø mm	Drilling depth mm	Article code
6	30	ETD0060000
8	35	ETD0080000
10	35	ETD0100000
12	35	ETD0120000
14	35	ETD0140000
16	35	ETD0160000
18	35	ETD0180000
20	35	ETD0200000



COOLDIP

Description	Article code
Wax container 20 ml	ETCD20ML00
Display with 9 pieces ETCD20ML00	ETCDDISP09



ACCESSOIRES

Description	Article code
Centring aid, stainless steel	BCH0410000
Dust extraction (page 130)	DPB0100000



Ø 5-6-8-10-12 mm



DIAMOND DRILLS FOR TILES AND STONE

DIAMOND DRILLS **CLASSIC**

for dry use on (cordless) drills

Ø mm	Drilling depth mm	Article code
6	30	ETDC006000
8	35	ETDC008000
10	35	ETDC010000
12	35	ETDC012000

Ø mm	Article code
Set Ø 6-8-10-12 mm	ETDCSET010
Set Ø 6-6-8-8 mm	ETDCSET020



ACCESSORIES

Description	Article code
Centring aid, stainless steel	BCH0410000
Dust extraction (page 130)	DPB0100000



Ø 5-6-8-10-12 mm



DIAMOND DRILLS FOR TILES AND STONE



DIAMOND DRILL KITS

for dry use on angle grinders

- Drills with M14 connector.
- Delivered in a transport case.

Description	Article code
Set of drills Ø 6-8-10-12-20-27-35 mm	EHSSET04NF
Set of drills Ø 20-27-35-55-72 mm	EHSSET02NF



DIAMOND DRILLS **MASTER**

Ø mm	Drilling depth mm	Article code
6	30	EHS0060706
8	30	EHS0080706
10	30	EHS0100706
12	30	EHS0120706
20	40	EHS0200706
27	40	EHS0270706
32	40	EHS0320706
35	40	EHS0350706
40	40	EHS0400706
50	40	EHS0500706
55	40	EHS0550706
60	40	EHS0600706
68	40	EHS0680706
72	40	EHS0720706
75	40	EHS0750706
82	40	EHS0820706
92	40	EHS0920706
102	40	EHS1020706
112	40	EHS1120706
132	40	EHS1320706



DIAMOND DRILLS **CLASSIC**

for dry use on angle grinders

Ø mm	Drilling depth mm	Article code
6	30	EHSC006000
8	30	EHSC008000
10	30	EHSC010000
12	30	EHSC012000

Ø mm	Article code
Set Ø 6-8-10-12 mm	EHSCSET010
Set Ø 6-6-8-8 mm	EHSCSET020





DIAMOND MILLING

STRAIGHT

for dry use on angle grinders

- Straight diamond milling to make new or existing holes in porcelain, ceramics, granite and marble.

Ø mm	Connection	Article code
5	M14	EHM0050656
10	M14	EHM0100656
20	M14	EHM0200656



CONICAL

for dry use on angle grinders

- Conical diamond cutters for making new or existing holes in porcelain, ceramics, granite and marble.

Ø mm	Connection	Article code
2-38	M14	EHM0380406
20-48	M14	EHM0480406



DIAMOND HAND SANDING BLOCKS AND POLISHING PADS



DIAMOND HAND SANDING BLOCKS EHP

- Flexible diamond hand sanding blocks for dry or wet use.
- Editing corners, edges, small surfaces and hard to reach places.
- Suitable for terrazzo, granite, marble, concrete, other natural stone, polyester and plastics.
- Available in grain: 60-120-200-400.
- Sweetened finish (matte dull finish) this is a finish that everyone can accomplish with any material. You only need to use grains 60, 120, 200 and 400. This is a finish without risk.

Sanding surface mm	Grain	Article code
90 x 55	60	EHP0600000
90 x 55	120	EHP1200000
90 x 55	200	EHP2000000
90 x 55	400	EHP4000000



60



120



200



400

DIAMOND POLISHING PADS EGP Ø 125 MM

- Diamond polishing disc with velcro.
- For dry use on smooth surfaces and beveled edges.
- Suitable for terrazzo, granite, marble and other natural stone types.
- Available in grit: 50-100-200-400-800-1,500-3,000.
- Buff black and white, for the final step for protection, smoothing and shine.
- Rubber backing pad Ø 125 mm with Velcro and M14 connection.

Ø mm	Connection	Grain	Article code
125		50	EGP0500000
125		100	EGP1000000
125		200	EGP2000000
125		400	EGP4000000
125		800	EGP8000000
125		1500	EGP1500000
125		3000	EGP3000000
125		BUFF BLACK	EGPBUFFBL00
125		BUFF WHITE	EGPBUFFWH00
125	M14 HOLDER		EGPHLD1250

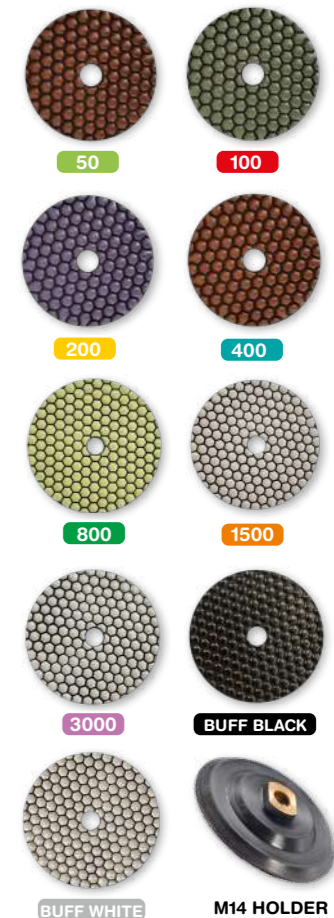

BUFF WHITE

M14 HOLDER



DRILLS

	Page
Choosing the right drill machine	108
Hand-held drill machine	109

Four key questions when choosing the right drill machine:

1

What material is it for?

The diamond drill range uses three colour codes:

- Brick Use in brick and sand-lime blocks (with dust extraction).
- Concrete Use with water cooling in (reinforced) concrete and hard materials.
- Dry Concrete Use without water cooling in channel plates and (reinforced) concrete.

You can select the most suitable drill from the table below.

Drilling range Ø mm	Type	Type	See page	Power output	Speeds
31 → 152	Hand-held	A-1810	109	1.8kW	1
14 → 70	Hand-held	A-1811	110	1.8kW	2
14 → 120	With stand	A-1811	110	1.8kW	2
14 → 70	Hand-held	A-1821	111	1.8kW	2
32 → 162	Hand-held	A-1821	111	1.8kW	2
14 → 120	With stand	A-1821	111	1.8kW	2
32 → 172	With stand	A-1821	111	1.8kW	2
14 → 70	Hand-held	A-2011	112	2.0kW	3
32 → 162	Hand-held	A-2012			
14 → 151	With stand	A-2011	112	2.0kW	3
32 → 201	With stand	A-2012			
14 → 70	Hand-held	A-2031	113	2.0kW	3
32 → 162	Hand-held	A-2032			
14 → 151	With stand	A-2031	113	2.0kW	3
31 → 201	With stand	A-2032			
46 → 250	With stand	AS-2512	122	2.5kW	3
46 → 350	With stand	AS-3312	123	3.3kW	3
DRY CONCRETE					
52 → 72	Hand-held	A-2225	115	2.2kW	1
52 → 162	With stand	A-2225	115	2.2kW	1



Dust extraction



Spirit levels

A-1810 DUSTEC® DIAMOND DRILL
for use with dust extraction

- Fitted with Controtec®.
- Fitted with Dustec® drill chuck (DPB0310000) with 5/8"x16UNF to M16 connection.
- Including transport case.

Technical data	
Power kW (hp)	: 1.8 (2.5)
Voltage V	: 230
Gears	: 1
Revs under load, rpm	: 2,000
Drilling range hand-held in brick mm	: 152
Machine connection	: 5/8"x16UNF
Machine connection with drill chuck	: M16
Weight kg	: 4.5
Article code	: AMB1810000DT
Drills for this machine	
Wall sockets	: 91
Brick / abrasive stone materials	: 92/93/94



2

With or without water cooling?

3

Which diameters now and in future?

4

Hand-held or with a drill stand?

Or is a combination of both required?



Controtec is a unique piece of intelligent software that protects Carat drill motors against electrical and mechanical overloads.

Advantages of the Controtec:

- The operator can see and feel when the motor is overloaded.
- The mechanical slip clutch is activated a great deal less.
- Maximum torque available at any speed.
- Faster and more efficient drilling process.
- Fewer repairs and lower maintenance costs.

A-1811 DIAMOND DRILL

for use with water cooling

- Including transport case and PRCD safety switch.
- The A-1811 can be used with the S-1801, S-1802, S-1803, S-1804 and S-1805 stands (see pages 118-121).



1/2" G connector



2 mechanical gears



Controtec®

Technical data	
Power kW (hp)	: 1.8 (2.5)
Voltage V	: 230
Gears	: 2
Revs under load:	
1st gear rpm	: 1,000
2nd gear rpm	: 2,600
Drilling range, hand-held in concrete, mm	: 70
Drilling range, from stand in concrete, mm	: 120
Machine connection	: 1/2" G
Weight kg	: 5.2
Article code	: AMB1811000

Drills for this machine	Page
Concrete / hard stone	: 82/83/84



Nastroc® quick change system



2 mechanical gears



Controtec®

A-1821 NASTROC® DIAMOND DRILL

for use with water cooling or dust extraction

- Including transport case and PRCD safety switch.
- The A-1821 can be used with the S-1801, S-1802, S-1803, S-1804 and S-1805 stands (see pages 118-121).

Technical data	
Power kW (hp)	: 1.8 (2.5)
Voltage V	: 230
Gears	: 2
Revs under load:	
1st gear rpm	: 1,000
2nd gear rpm	: 2,600
Drilling range, hand-held:	
in concrete mm	: 70
in brick mm	: 162
Drilling range, from stand:	
in concrete mm	: 120
in brick mm	: 172
Machine connection	: NT-Nastroc
Weight kg	: 5.6
Article code	: AMB1821000

Drills for this machine	Page
Concrete / hard stone	: 82/83/84
Brick / abrasive stone materials	: 95



A-2011/A-2012 DIAMOND DRILL MACHINES

for use with water cooling or with dust extraction.

- Including aluminum protection case.
- The A-2011/A-2012 can be used with the S-1801, S-1802, S-1803, S-1804 and S-1805 stands (see pages 118-121).



Combination shaft, 1/2" G and 5/4" UNC



3 mechanical speeds



Controtec®

Technical details	
Power kW (hp)	: 2.0 (2.7)
Voltage V	: 230
Speeds	: 3
RPM under load:	
1st speed rpm	: 450
2nd speed rpm	: 1,050
3rd speed rpm	: 2,000
Drill range handheld:	
in concrete mm	: 70
in brick mm	: 162
Drill range from stand:	
in concrete mm	: 201
in brick mm	: 201
Machine connection	: 1/2" G + 5/4" UNC
Weight kg	: 6.7

	A-2011	A-2012
Handle	Back handle	Pistol handle
Article code	AMB201100I	AMB201200I
Drills for these machines		Page
Concrete / hard stone materials		: 85



M30



3 mechanical gears



Controtec®

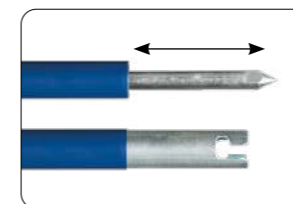

Bayonet with centre point suspension

A-2031/A-2032 M30 DIAMOND DRILLS

for use with water cooling or dust extraction

- Including transport case.
- The A-2031/A-2032 can be used with the S-1801, S-1802, S-1803, S-1804 and S-1805 stands (see pages 118-121).

Technical data	
Power kW (hp)	: 2.0 (2.7)
Voltage V	: 230
Gears	: 3
Revs under load:	
1st gear rpm	: 450
2nd gear rpm	: 1,050
3rd gear rpm	: 2,000
Drilling range, hand-held:	
in concrete mm	: 70
in brick mm	: 162
Drilling range, from stand:	
in concrete mm	: 160
in brick mm	: 201
Machine connection	: M30
Weight kg	: 6.7

	A-2031	A-2032
Hand grip	Rear hand grip	Pistol hand grip
Article code	AMB2031000	AMB2032000

Drills for this machines		Page
Concrete / hard stone		: 82/83/84
Brick / abrasive stone materials		: 95

Centring pins for these machines	
Length mm	Article code
70	BCHC001300
300	BCHC003000
400	BCHC004000



A-2031/A-2032 DIAMOND DRILL SET

- 4 Master diamond drills Ø 31-51-81-131 x 400 mm in case.
- M30 connection.

Article code	- pistol hand grip	: AMB2032S01
	- rear hand grip	: AMB2031S01

DIAMOND DRILLMACHINE KIT **MASTER**
(diamond drill machine not included)

- Ø 31-51-81-131 x 400 mm in case.
- M30 connection.

Article code	: EMSET010NL
--------------	--------------



Dry Concrete drills



5/4" UNC connection



Integrated vacuum cleaner connection

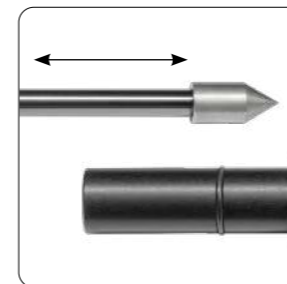

Centering pin with spring pin

A-2225 **DRY BETON**

for use with dust extraction

- Suitable for dry drilling in concrete and brick with DRY BETON drills.
- With switchable micro knock function of 28,800 rpm that the drilling in the hardest materials accelerates and ensures proper drainage of it drill cuttings.
- With integrated vacuum cleaner connection.
- Overload protection and slip clutch.
- For air conditioning installers to drill dry in concrete freehand up to Ø 72 mm.
- The A-2225 must always be used in combination with a vacuum cleaner.

Technical data	
Power kW (hp)	: 2.2 (2.8)
Voltage V	: 230
Gears	: 1
Revs under load, rpm	: 880
Drilling range, hand-held:	
in concrete mm	: 72
in brick mm	: 162
Drilling range, from stand:	
in concrete mm	: 162
in brick mm	: 162
Machine connection	: 5/4"UNC
Weight kg	: 5.6
Article code	: AMB2225000

centering pins for this machine	
Drill length mm	Article code
60	BCHCC51000
300-420	BCHCC10000





DRILL STANDS DRILL SYSTEMS

	Page
Stands for hand-held drills	118
Diamond drill systems	122
Accessories	125

S-1801 DRILL STAND

- Aluminum stand with adjusting bolts.
- The control handle can be installed on either side.
- Adjustable guide.

Technical data	
Max. drill diameter mm	: 140
Max. drill length mm	: 450
Ø clamp collar mm	: 60
Weight kg	: 7
Article code	: ASB1801000



Centre arrow



Spirit level in clamp seat



Compact base



Max. drill diameter 201 mm



Spirit level in clamp seat



Suitable for vacuum kit



Stand for hand-held drills



Ergonomic carrying handle

S-1803X DRILL STAND

- Robust stand designed in aluminum with telescopic buttress.
- The control handle can be installed on either side.
- Adjustable guide.
- Base plate suitable for use with quick release clips or vacuum set.

Technical data	
Max. drill diameter 90° mm	: 201
Max. drill diameter 45° mm	: 121
Max. drill length mm	: 530
Ø clamp collar mm	: 60
Weight kg	: 10
Article code	: ASB1803X00



S-1804 DRILL STAND

- Drilling holes safely and fast in sewage pipes.
- Aluminum construction with pressure springs.

Technical data	
Max. drill diameter mm	: 250
Max. drill length mm	: 300
Ø clamp collar mm	: 60
Weight kg	: 6
Article code	: ASB1804000



Locking



2 transportwheels



Including water collection ring



Horizontal drill stand

S-1805N

- For drilling into ceilings quickly and professionally.

Technical data	
Max. drill diameter mm	: 170
Max. drill length mm	: 450
Ø clamp collar mm	: 60
Working height m	: from 1.8 till 3
Weight kg	: 35
Article code	: ASB1805017

HORIZONTAL DRILL STAND

- Accessories for horizontal and safe drilling on the drill stand S-1805N.

Technical data	
Max. drill diameter mm	: 200
Max. drill length mm	: 400
Article code	: ASB1805HOR



AS-2512 COMPLETE DRILL KIT

- Suitable for drilling with water cooling in reinforced concrete.
- Motor with 3-way protection against overload.



5/4"UNC



3 mechanical gears



Stable base plate with wheels



Centre arrow

Technical data	
Power kW (hp)	: 2.5 (3.4)
Voltage V	: 230
Gears	: 3
Revs under load:	
1st gear rpm	: 200
2nd gear rpm	: 400
3rd gear rpm	: 590
Drilling range, from stand in concrete, mm	: 250
Machine connection	: 5/4" UNC
Weight kg	: 21.5
Article code	: ASB2512L00

Drills for this machine	Page
Concrete / hard stone materials	: 82-85

Accessories	Article code
Stand	: ASB2300000
Motor seat for hand-held drill collar Ø 60 mm	: BSM2300000



Controtec®



3 mechanical gears



Integrated wheels



Reduction gear

AS-3312 COMPLETE DRILL KIT

- Suitable for drilling with water cooling in reinforced concrete.
- Motor with 3-way protection against overload.

Technical data	
Power kW (hp)	: 3.3 (4.5)
Voltage V	: 230
Gears	: 3
Revs under load:	
1st gear rpm	: 230
2nd gear rpm	: 510
3rd gear rpm	: 730
Drilling range, from stand in concrete, mm	: 350
Machine connection	: 5/4" UNC
Weight kg	: 32
Article code	: ASB3312000

Drills for this machine	Page
Concrete / hard stone materials	: 82-85

Accessories	Article code
Stand	: ASB3000000



S-3010 DRILL STAND

- For drilling into floors, walls or ceilings quickly and professionally.
- No anchoring required: the ceiling jack is integrated in the vertical column.
- The horizontal column can be rotated 360 degrees.
- Drilling can be done at any angle.
- The drill stands can also be used separately.

Technical data

Max. drill diameter mm	:	300
Max. drill length mm	:	1,500 vertical 500 horizontal
Working height m	:	from 2 to 3.5
Weight kg	:	46
Article code	:	ASB3010000

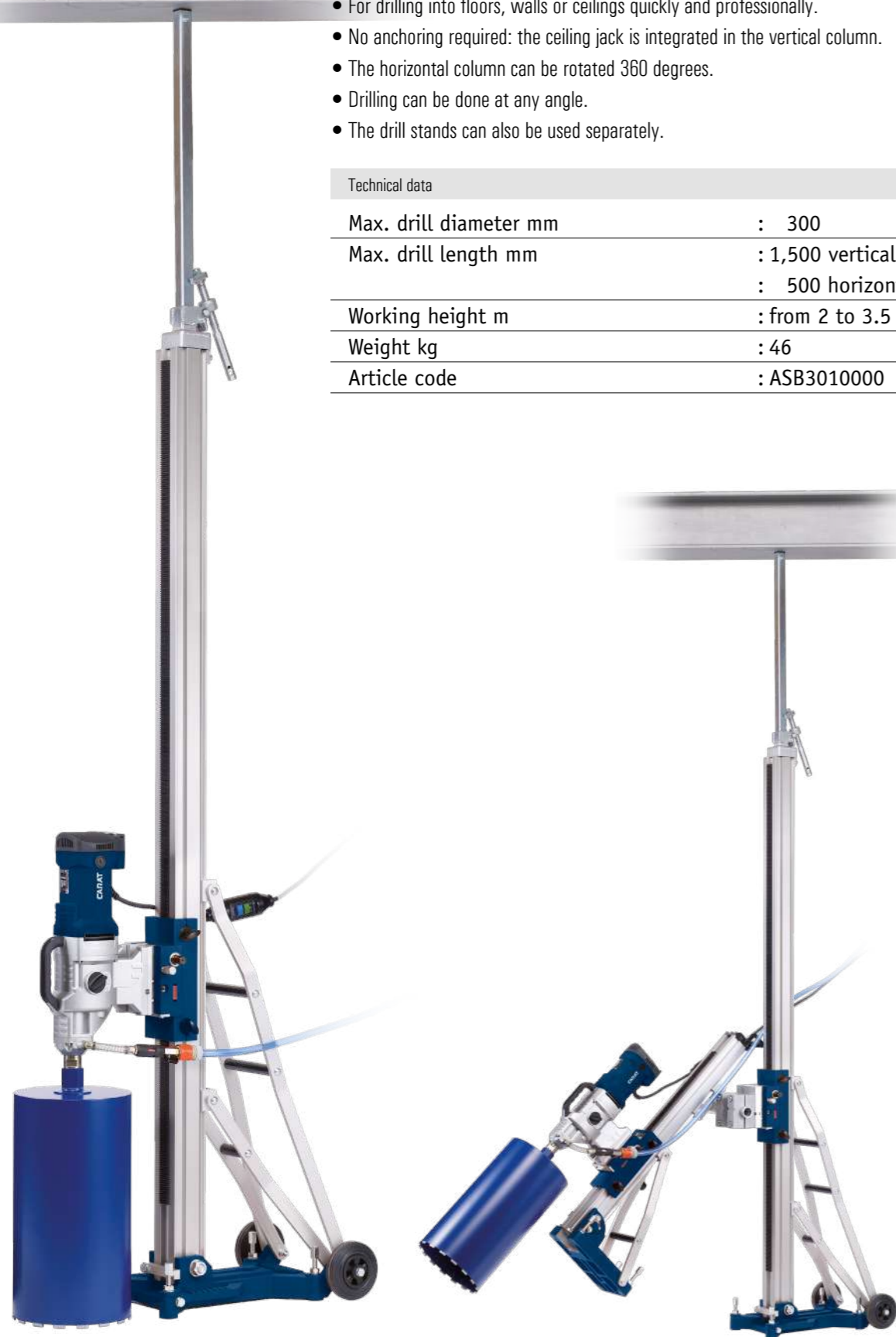

WATER COLLECTION RINGS, including 3 rubber covers

Description	Article code
For drill stand S-1801 up to Ø 130 mm	BSW1801000
For drill stands S-1802 and S-1803 up to Ø 130 mm	BSW1802000
For drill stands S-2300 up to Ø 180 mm	BSW2300000



VACUUM KIT ACCESSORIES for S-1803 and S-2300 drill stands

Description	Article code
Vacuum pump, complete	BA04B00000
Vacuum connector	BSV0000000
Rubber ring for S-1803	BSV1802000
Rubber ring for S-2300	BSV2300000



PRESSURE TANK

Description	Liter capacity	Article code
Metal	10	KDDW220000
Plastic	10	KDDW100000



MODULAR JACK COLUMN

for S-1801, S-1802, S-1803 and S-2300 drill stands

Description	Article code
Guide rail 3.10 m	BSS0000000



FILLING BLOCK S-2300 / S-3000

extends the maximum drill diameter by 50 mm

Description	Article code
	BSVB0000000

MISCELLANEOUS

Description	Article code
Quick release clamp, wing nut and washer for M12 anchor M12	BA03ZA0000
Grindstone for sharpening diamond drills and blades	BH00000000
Water supply pump	BB05100000
U-plate for sewage pipe drills	BE12000000
M12 anchor set, complete 50 anchors Ø 15 mm, quick-release clamp, washer and wing nut	BA03AK0000
Anchor set for soft material (bricks/lime stone) M12 Complete set incl. drill SDS+ 24mm	BA01AR0000





DUST PROTECTION

	Page
Dust-free drilling	
Dust extraction and centre pins	130
Dust-free cutting and grinding	
Dust and protection covers for angle grinders	132
Dust-free working	
Dust extractor	133
Protective materials/cover sheets	134
Dust door and dust wall	135

DUST EXTRACTION and CENTRING AID UP TO Ø 12 MM

- Collects dust while drilling.
- Connect to a vacuum cleaner and the dust extraction sticks to the wall, floor or ceiling.
- For drilling up to a maximum of Ø 12 mm.

Article code
DPB0100000



DUST EXTRACTION and CENTRING AID UP TO Ø 72 MM

- Collects dust and water while drilling.
- Connect to a vacuum cleaner and the dust extraction sticks to the wall, floor or ceiling.
- For drilling up to a maximum of Ø 72 mm.

Article code
DPB0200000



DUST PROTECTION DRILL HOLDER

- For collecting dust while drilling with Dustec® diamond drills.
- Available with connections for all common drills.
- Can be used with a centring pin.

Machine connection	Article code
5/8" x 16UNF	DPB0310000
M18 x 2.5	DPB0320000
1/2" x 20UNF	DPB0330000
13 mm drill chuck	DPB0340000
SDS plus	DPB0350000
M16 x 2.0	DPB0360000
1/2"G	DPB0370000
M16 + hexagon + SDS spindle + ctr.pin	DPB0380000
Dustec rubber seal	ZANT050000



"TWIN" DUST EXTRACTION

- Collects dust while drilling.
- Also used as a centring aid and spacer for drilling multiple holes next to one another.
- Connect up to a vacuum cleaner and the dust extraction sticks to the wall, floor or ceiling.
- For box drills Ø 82 mm.

Article code
DPB0400000



"TWIN" DUST EXTRACTION SET

- This set consists of "Dust extraction for Dustec® diamond drills" (1) and "Twin dust extraction for box drills" (2).
- The Y-piece supplied (3) makes it possible to connect both adapters to just a single vacuum cleaner.

Machine connection	Article code
5/8" x 16UNF	DPB0510000
M18 x 2.5	DPB0520000
1/2" x 20UNF	DPB0530000
13 mm drill chuck	DPB0540000
SDS plus	DPB0550000
M16 x 2.0	DPB0560000
1/2"G	DPB0570000



DUST and PROTECTION COVER

for angle grinders Ø 125 mm

- Dust and protection cover in one.
- Fast dust extraction.
- Let you work faster.
- Can be mounted easily to all common angle grinders from Metabo, Dewalt, Hitachi, Bosch, Flex, Makita and Milwaukee.

Article code

DPZ0100000



HEAVY-DUTY DUST and PROTECTION COVER

for angle grinders Ø 125 mm

- Dust cover and protection cover in one.
- Fast dust extraction.
- Let you work faster.
- Can be mounted easily on all common angle grinders from Metabo, Dewalt, Hitachi, Bosch and Makita.

Ø mm

Article code

125

DPZ1250000



DUSTCATCH PRO DUST and PROTECTION COVER

for angle grinders Ø 180 and 230 mm.

- Dust cover and protection cover in one.
- Fast dust extraction.
- Suitable for blades Ø 180-230 mm.
- Can be mounted easily on all common angle grinders from Metabo, Dewalt, Hitachi, Bosch and Makita.

Technical data

Suitable for blades Ø mm : 180-230

Cutting depth mm:

- with blade Ø 180mm : 5-35 mm

- with blade Ø 230mm : 5-60 mm

Weight kg : 2.4

Article code : DPZ230NK00



Universal mounting

DUST and PROTECTION COVER

for angle grinders Ø 125 mm

- Dust and protection cover in one.
- Fast dust extraction.
- Lets you work faster.
- Can be mounted easily to all common angle grinders from Metabo, Dewalt, Hitachi, Bosch, Flex, Makita and Milwaukee.

Article code

DPSK010000



DUSTCATCH-PRO DUST and PROTECTION COVER

for angle grinders Ø 180 and 230 mm

- Universal dust cover.
- Fast dust extraction.
- Suitable for 180 mm grinding cups.
- Can be mounted easily to all common angle grinders from Metabo, Dewalt, Hitachi, Bosch, Flex, Makita and Milwaukee.

Article code

DPSK180000

Brush set

XDPSKSDCC1



DOORMAT

- Ideal for work in rooms that are in use.
- Prevents dust trails from shoes on carpets and solid floors.
- 1 doormat consists of 30 numbered sheets of 640 x 1140 mm.

Article code

DPM0100000



COVERING SHEET FOR HARD SURFACES

- Self-adhesive and easy to apply.
- Protects the floor during light construction and/or painting work.
- Can also be used in cars, boats and caravans.
- UV protection.
- Can be removed easily after use without glue residues.

Description	Article code
1 roll (25 x 0.7 m)	DPF0100000



COVER SHEET FOR FLOOR COVERINGS

- Self-adhesive and easy to apply.
- Protects the floor during light construction and/or painting work.
- Can also be used in cars, boats and caravans.
- UV protection.
- Can be removed easily after use without glue residues.

Description	Article code
1 roll (25 x 0.7 m)	DPF0200000



DECOILER

- Self-adhesive cover sheet that can be applied easily to floor coverings or hard surfaces.
- Ideal for large surfaces.
- To be used with DustProtect covering sheets for floor coverings and DustProtect covering sheets for hard surfaces.

Description	Article code
	DPFR010000



COVER FELT

- Cover felt to protect various vulnerable surfaces such as parquet and laminate flooring.
- Absorbs shocks and protects against liquids, paint, oil and cement.
- Can be re-used multiple times.

Description	Article code
1 roll (10 x 1.0 m)	DPF0300000



DUST DOOR

- Self-adhesive and easy to apply.
- Zip on 2 sides.
- Stops dust and odours.
- Reusable.
- Suitable for doors up to 1 meter wide and 2.1 meter high.
- Including attachment tape.

Description	Article code
Dustprotect dustdoor	DPD0100000



SELF-ADHESIVE ZIPPER

- Create a lockable passage easily in curtain walls.
- One pack contains 2 solid self-adhesive 2-meter zippers.

Description	Article code
	DPR0100000



REMOVABLE DUST WALL

- Create a fully dust-free room by yourself in just 10 minutes.
- Ideal when renovating and rebuilding.
- Keeps dust away from other sections of the building.

One pack contains:

- 2 x sheets (4x5 meter).
- 4 telescopic holders 3.8 meter. Also single available.
- 8 mounting plates.
- 4 sheet clamps.
- 2 rolls of tape.
- 8 tube clamps.
- 2 self-adhesive zips.
- Carrier bag.

Description	Article code
	DPW0100000





CONDITIONS OF SALE

	Page
General terms and conditions of sale	138

General Conditions of Sale Carat Nederland B.V.

1. The user of these Conditions of Sale is Carat Netherlands B.V., a private limited liability company under Dutch Law (Chamber of Commerce no. 20061250), hereinafter referred to as: "Carat" in these Conditions of Sale. Buyer and/or Customer are taken to mean the natural or legal person that, while exercising his profession or running his business, places an order with Carat and by doing so enters into a purchase agreement with Carat, whether or not through a Carat sales representative.
2. These Conditions of Sale shall apply to all orders which have been placed with Carat and all activities resulting from this purchase agreement as well as to related legal relationships. All transactions between Carat and the Buyer shall take place in accordance with these Conditions of Sale which are also filed at the office of the Chamber of Commerce in Breda under number 2287. These Conditions of Sale may only be deviated from in written form and only to the extent of one order.
3. The offers and prices of Carat, including those stated in the catalogues and on the official lists, are without obligation and subject to changes. Carat is entitled to deviate from these prices, also after the purchase agreement has been concluded, especially in the cases where the cost price of the products sold is increasing as a result of pay rises, increased material prices, price changes or other factors. If Carat changes the prices quoted, it will state the reason for doing so.
4. All prices are inclusive of packaging and exclusive of VAT and disposal contribution. Orders from outside The Netherlands and under EUR 136.00 will be subject to freight charges.
5. The products supplied by Carat which do not meet the criteria set for them on the basis of the social standard and, due to this, are not suitable for use, may be returned to Carat. The products in question will be replaced or credited, such at the discretion of Carat.
6. The risk of the products which form part of the purchase agreement between Carat and the Buyer will pass to the Buyer at the moment that the products leave the Carat company or warehouse.
7. In the event of force majeure including work strikes and problems related to the suppliers of Carat, Carat shall not be obliged to make a delivery. The Buyer cannot claim termination or damages by virtue of breach of contract as a result of the aforementioned force majeure.
8. Carat shall not be liable for damage and/or loss as a result of a defect in any product and/or the use of any defective product, material or manufacturing deviations or damage and/or loss which occurred otherwise, except for intent or gross negligence. Carat is willing, however, to transfer any claim that it has against the supplier/manufacturer of the products based on the foregoing, to the Buyer in so far as this claim is related to the damage and/or loss of the Buyer.
9. The Buyer's right to file a complaint will lapse fourteen (14) days after receipt of the ordered products.
10. The Buyer must pay the invoice within thirty (30) days after invoicing. This is considered to be a final deadline as defined in Section 83 sub a of Book 3 of the Dutch Civil Code (BW) on the basis of which default will occur without further notice of default. The statutory interest will be owed from the due date. If Carat must take action to recover a debt, all reasonable judicial and extrajudicial collection costs will also be owed. The extrajudicial collection costs shall be 15% of the invoice amount with a minimum of EUR 150.00.
11. Carat shall retain the explicit ownership of the delivered products until the Buyer has paid the full invoice amount of these products. The payment will be considered as a suspensive condition as defined in Section 22 of Book 6 of the Dutch Civil Code. On demand, the Buyer must return the non-paid products to Carat. The Buyer hereby also grants permission to Carat or to a representative of Carat, to enter the room where the products are stored and to revendicate the products itself.
12. The purchase agreement between Carat and the Buyer shall be governed by Dutch law. Any dispute arising from the purchase agreement will be submitted to the competent court in Breda.
13. Insofar as Personal Data is processed within the framework of the execution of the Agreement, this Personal Data will be processed properly and with due care, in accordance with the General Data Protection Regulation ("GDPR").
14. Carat will take technical and organisational measures to protect the Personal Data against loss or any other form of unlawful processing, taking into account the prior art and the nature of the processing.
15. If during the execution of the agreement Carat processes Personal Data, it will process the Personal Data properly and with due care and comply with the legal requirements under the GDPR. The Personal Data that has been obtained is to be used for the purpose of the agreement only. This data will not be retained for any longer than is necessary for that purpose and must be properly protected.
16. The Buyer agrees to these Conditions of Sale unless he has communicated the contrary in writing. The purchase conditions of the Buyer are explicitly renounced.
17. Carat shall not be liable for any mistakes or incorrectly stated data in the catalogues, brochures, offers, order confirmations or invoices. Nor shall Carat be obliged to deliver or sell on the basis of these incorrectly stated data.

CARAT



Experience Carat



CARAT NEDERLAND B.V.
Nikkelstraat 18
4823 AB Breda
The Netherlands

Tel: +31 (0)176 5 422 422
sales@carat-tools.nl
www.carat-tools.eu